BLAKES LAVAC TAYLORS

BLAKES marine toilets

Owners Handbook

Blakes Lavac Taylors Ltd.

Schiffsausrüster

TOPLICHT

Tel.: +49 (0)40 - 88 90 100

Fax: +49 (0)40 - 88 90 1011

toplicht@toplicht.de

www.toplicht.de

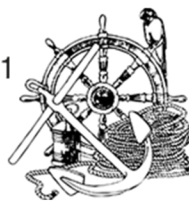

Table of Contents

| | |
|---|------------------|
| 1. INTRODUCTION | Page – 1 |
| <hr/> | |
| 2. INSTALLATION KIT REQUIRED | Page – 2 |
| <hr/> | |
| 3. EXPLODED DIAGRAMS | Page – 3 |
| <hr/> | |
| 4. SPARE PARTS REFERENCE NUMBERS | Page – 19 |
| <hr/> | |
| 5. INSTALLING YOUR MARINE TOILET | Page – 26 |
| <hr/> | |
| 5.1. SITING AND INSTALLING THE SEACOCKS | 26 |
| 5.2. SITING AND INSTALLING THE TOILET (utilising current modifications in clack valve) | 27 |
| 5.2.1 SITING BELOW THE WATERLINE | |
| 5.2.2 SITING ABOVE THE WATERLINE | |
| 5.2.3 GENERAL | |
| 5.2.4 HOLDING TANK INSTALLATIONS | |
| 5.2.5 INSTALLATIONS WITH A WASHBASIN | |
| <hr/> | |
| 6. OPERATING YOUR MARINE TOILET | Page – 29 |
| <hr/> | |
| 7. MAINTAINING YOUR MARINE TOILET | Page – 30 |
| <hr/> | |
| 7.1. GENERAL | 30 |
| 7.2. REMOVING THE TOILET UNIT | 32 |
| 7.3. SERVICING THE DISCHARGE PUMP | 32 |
| 7.3.1 BABY & MINOR MODELS | |
| 7.3.2 VICTORY MODEL | |
| 7.4. SERVICING THE FLUSHING PUMP | 41 |
| 7.4.1 GENERAL | |
| 7.4.2 ALL MODELS | |
| 7.5. REMOVAL AND REPLACEMENT OF THE WHEEL CONTROL VALVE ASSEMBLY | 46 |
| 7.5.1 ALL MODELS | |
| 7.6. SERVICING THE TOILET PAN | 47 |
| 7.6.1 BABY & VICTORY MODELS | |
| 7.6.2 MINOR MODEL | |
| 7.7. NOTES ON CLEANING AND REFITTING THE PARTS | 49 |
| 7.8. SERVICING OLDER MODELS | 49 |
| 7.9. PROCEDURE TO AVOID FROST DAMAGE IN WINTER | 49 |
| <hr/> | |
| 8. CHECK POINTS | Page – 51 |
| <hr/> | |
| 9. DIMENSIONS AND SPECIFICATIONS | Page – 53 |
| <hr/> | |

1. INTRODUCTION

Congratulations on your purchase of a Blakes Marine Toilet

Blakes Marine Toilets are firm favourites with sailors throughout the world, providing their owner with a long and trouble free working life. They are simple to operate. After use, separate pumping systems ensure that waste and clean water are never mixed.

Within this handbook you will find information and practical help on installing, operating and maintaining your marine toilet. If you require any further help or advice, please contact us either by Telephone +44 (0)1489 580580, Fax: +44 (0)1489 580581, or E-mail: info@blakes-lavac-taylors.co.uk or by writing to: **Blakes Lavac Taylors Ltd., 13 Harvey Crescent, Warsash, Southampton, SO31 9TA United Kingdom.**

Over many years, we have taken advice from sailors around the world concerning their requirements for marine equipment and our current range is a result of this ongoing commitment. If you have any comments or helpful hints that you would like to share with us, we would be very pleased to hear from you. As a result of past advice we have for example:

* Improved the sealing of the pump tops using a new lip seal. This is now



incorporated on all new toilets. You can easily upgrade your old toilet by either replacing the pumps with complete units or just replacing the pump tops (please check the condition of the pump spindle first). To order the required spare parts refer to **sections 3 and 4** of this handbook.

* Improved the seat and cover buffer. Its appearance is superior and is simply screwed in place. Again you can easily upgrade your present toilet and the spares code for ordering these is detailed in the handbook.

BLAKES TOILETS - PRODUCT UPDATE Oct'92

LATEST SPECIFICATION PUMP TOPS (in production from end 1992)

COMBINED GLAND PACKING & LIP SEAL PUMP TOPS:

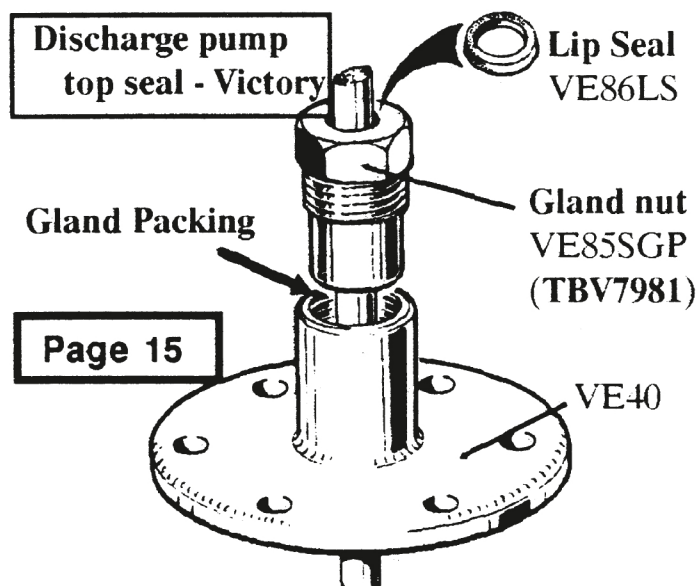
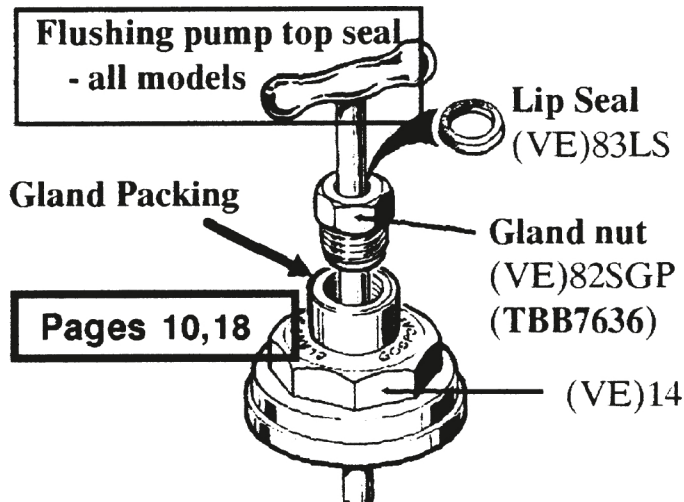
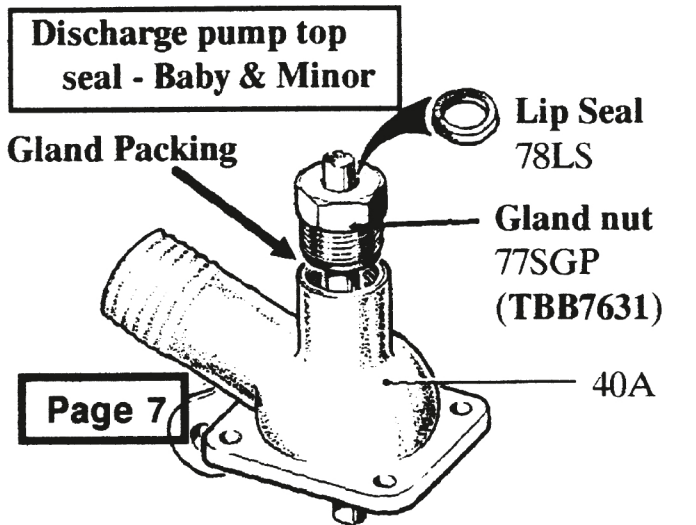

UPGRADING

The new type "double seal" pump tops, incorporating both a Lip Seal as well as Gland Packing, are a genuine improvement - **upgrading previous specifications is well worth the effort.**

Referring to pages 7,10,15,&18:

Previous specifications: lip seal incorporated within pump top **OR** the self-adjusting gland type require complete PUMP TOP ASSEMBLY replacements (Table B: Page 23). **Note that the old pump rod may also need replacing if badly worn.**

Previous specifications: lip seal incorporated in gland nut **OR** O-ring type **OR** gland packing type (pre-1962) can be upgraded by **either**: replacing the complete PUMP TOP ASSEMBLY **or**: 1). using gland packing instead of the O rings as O rings do not compensate so well for wear; **or**: 2). replace the old gland nut with the new ***SGP (Seal/Gland Packing) Gland Nut - this gives more space for gland packing as well as incorporating a superior Lip Seal. **Note that, with replacement of the gland nut only, there is a danger that the pump action will be stiff - if so, enlarge (ream out) the guiding hole in the pump top).**

Servicing and Spares details: P.T.O.

Amendment: dated Oct 1992 - page 1 of 2

BLAKES TOILETS - PRODUCT UPDATE Oct'92

SPARES

The following components in the new combined Gland Packing & Lip Seal pump tops have superceded those detailed in **Table A** (Pages 21 & 22) titled "**SPARES FOR CURRENT SPECIFICATION TOILETS - BABY, MINOR AND VICTORY MODELS**":

PUMP TOPS

- * **40A** supercedes **76ALS** (spares code remains as **TBB7555**)
- * **14** or **VE14** supercede respectively **81LS** or **VE81LS** (spares code remains as **TBB7296**)
- * **VE40** supercedes **VE84LS** (spares code remains as **TBV7870**).

The following components in the new combined Gland Packing & Lip Seal pump tops are added to those detailed in **Table A** (Pages 21 & 22) titled "**SPARES FOR CURRENT SPECIFICATION TOILETS - BABY, MINOR AND VICTORY MODELS**":

GLAND NUTS

- * **77SGP** (spares code **TBB7631**)
- * **82SGP** or **VE82SGP** (spares code **TBB7636**)
- * **VE85SGP** (spares code **TBV7981**)

SERVICING

When servicing the new combined Gland Packing & Lip Seal pump tops reference in **Chapter 7** titled "**MAINTAINING YOUR MARINE TOILET**" should be made to detail given for both the "**Lip seal type**" and "**Gland packing type[section dealing with]....pre-1962 models ...**".

The tremendous advantage of having a combined Gland Packing & Lip Seal pump top is that adjustments (by screwing down or unscrewing Gland Nut) or, replacement, of the Gland Packing seal can be done at any time; whilst the Lip Seal need only be replaced during major overhauls. The Lip Seal is a "secondary" seal and is only efficient over a long period if protected from serious wear by the Gland Packing. Its primary purpose is to expand under pressure and thus prevent "weeping" on the pump rod.

2. INSTALLATION KIT REQUIRED FOR YOUR BLAKES MARINE TOILET

Packed with your Blakes marine toilet should be self-adhesive operating instructions for fixing to the bulk head.

Certain components required for the installation are easier to source locally. It is best therefore, for you to purchase the following separately, depending on your requirements:

- 4 x 10mm (3/8") diameter Bronze securing bolts or screws for base (We can provide chromed Bronze bolts and dome nuts if required)
- Reinforced sanitation grade hose - length dependant on installation
- Hose clips (We can provide these if you are stuck)



'... and hurry!'

3. EXPLODED DIAGRAMS

BABY BLAKE & MINOR MODELS

(DIAGRAMS DETAIL OPTIONS AND OLD SPECIFICATION COMPONENTS)

Note: The diagram on this page shows the current specification Baby toilet. The Minor toilet is very similar and where it utilises different components these are specified on the relevant pages. Old specification components and options are also detailed. (Some options have been discontinued and these are also specified).

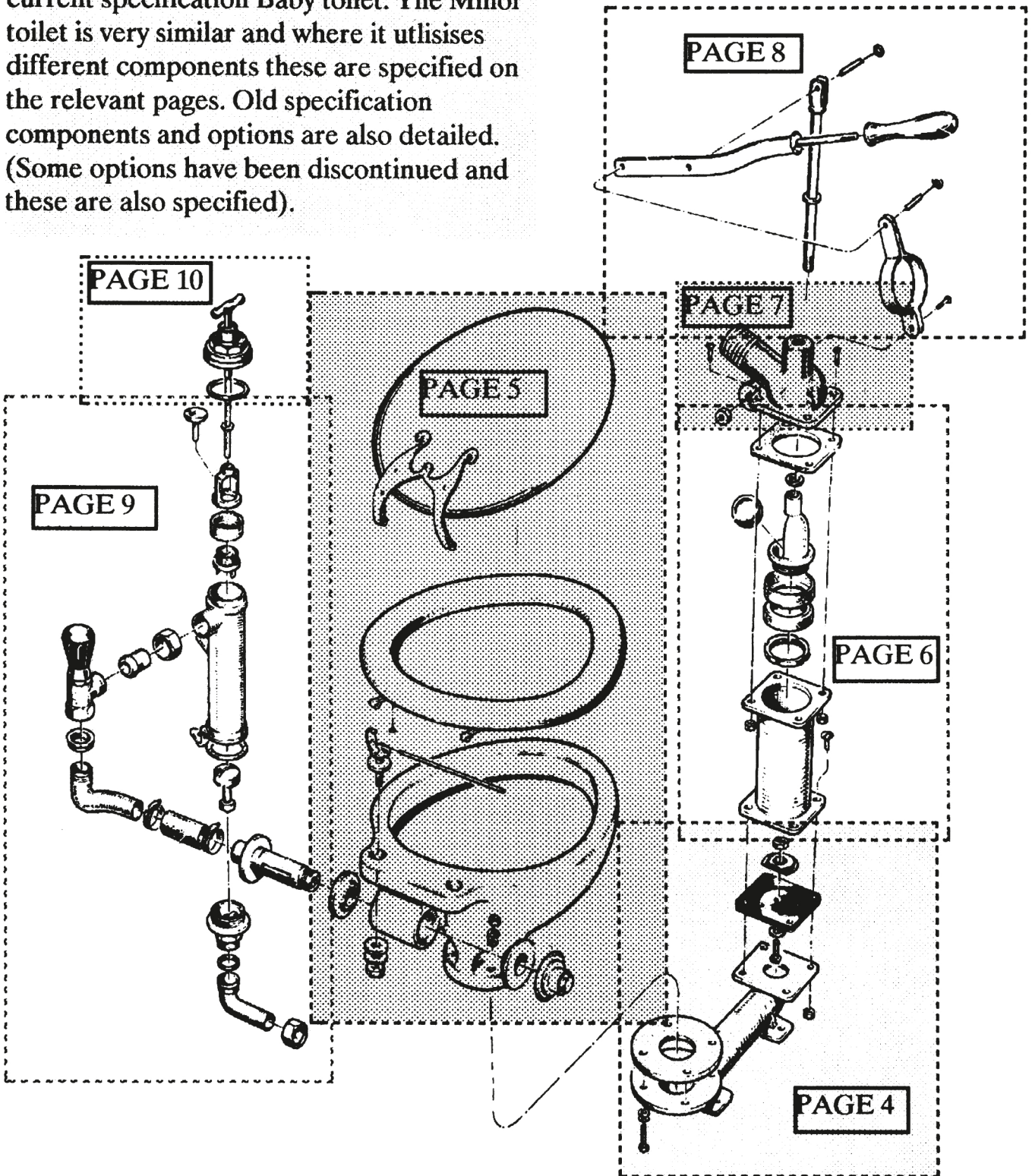

BABY BLAKE & MINOR MODELS

Toilet Base assembly

DEFINITION OF RIGHT HAND TOILET OPTION: This is the standard option. Pumps are on the right of the toilet pan (59A or 59) when facing the front of the toilet.

LEFT HAND OPTION: Available on request. Pumps are on the left of toilet pan when facing the front of the toilet.

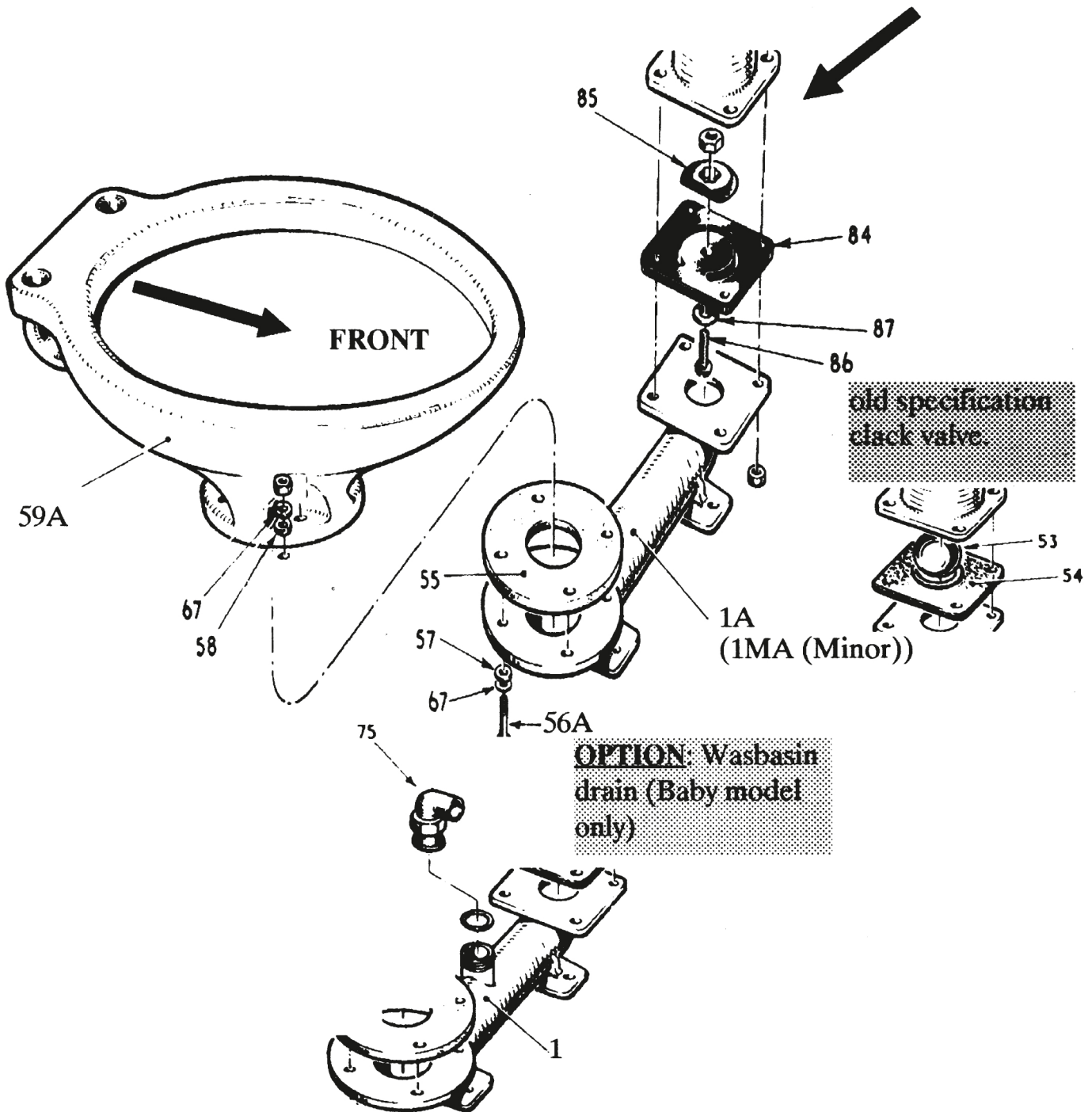

BABY BLAKE & MINOR MODELS

Toilet pan assembly

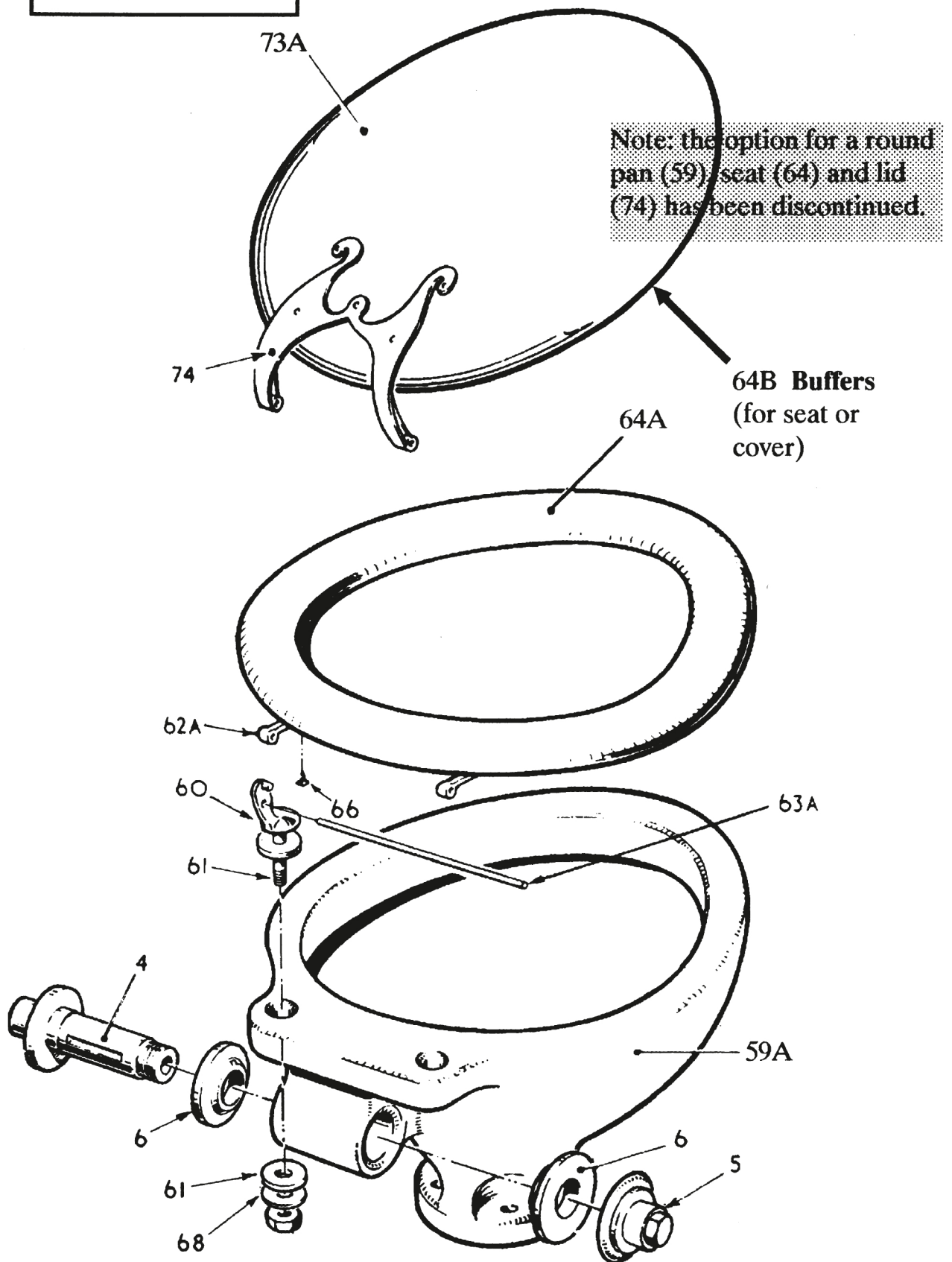

BABY BLAKE & MINOR MODELS

Discharge pump assembly

Note: standard outlet is Hose connection.
Optional outlet is Cap & lining

PAGE 7
OUTLET
OPTION

PAGE 7
SEAL
SPECIFICATION

Note: there are 5 specifications including current lip seal type. The current specification can be fitted to upgrade from any previous specification.

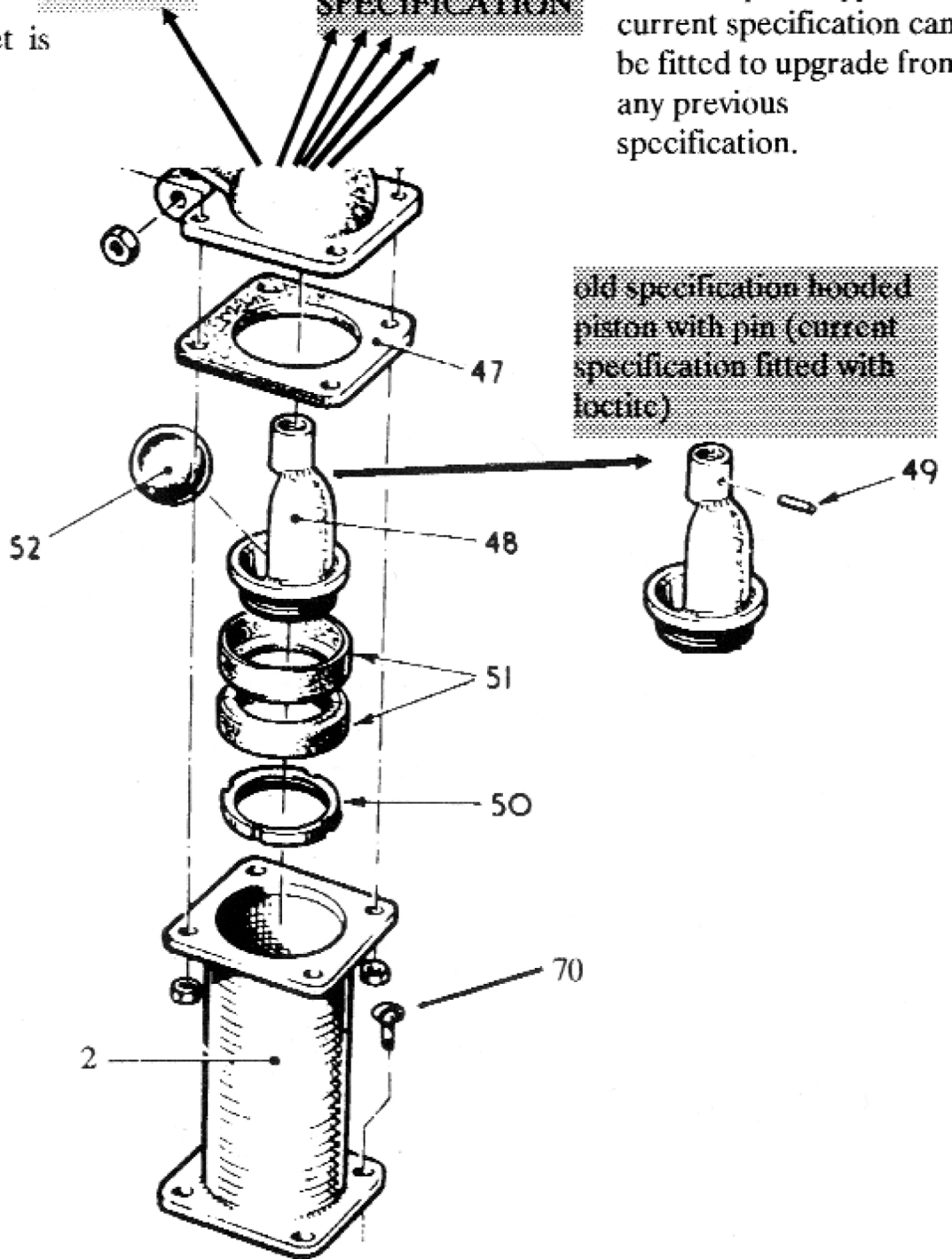

BABY BLAKE & MINOR MODELS

Discharge pump top seal

LIP SEAL TYPE

Current specification (from May 1992)

specification from end 1991 - Apr 1992

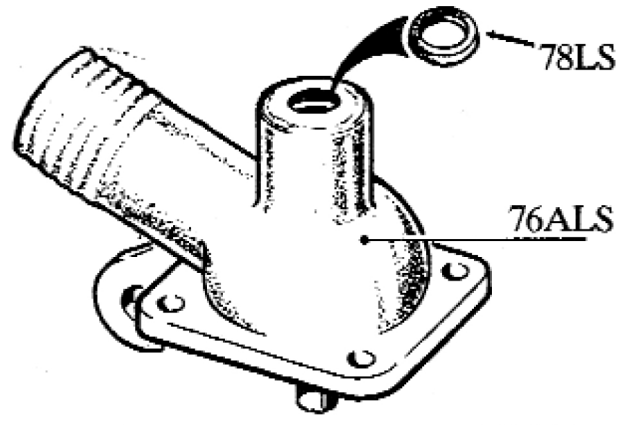
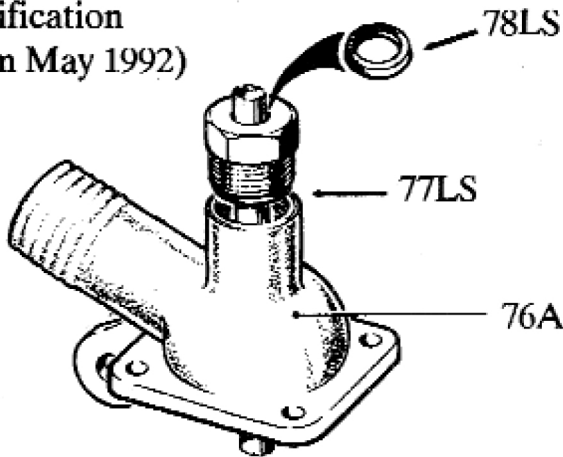

HOSE CONNECTION OUTLET fitted as standard

OPTION: Cap & lining outlet: 76, 77LS, 78LS, 45, 46 (Note: fixing/removal of discharge hose is by threaded nut (cap))

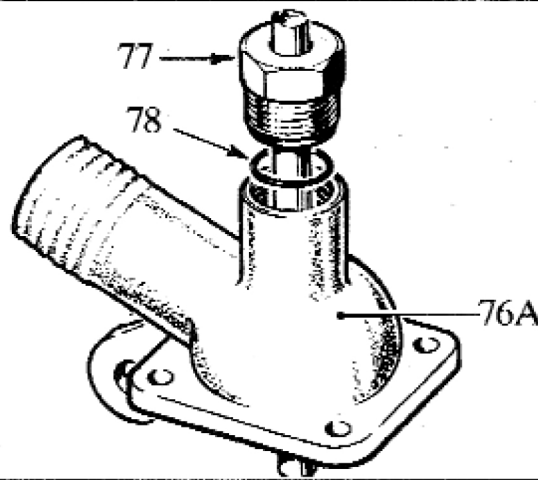

O-RING TYPE

specification from October 1974 - end 1991

GLAND PACKING TYPE

Self-adjusting gland type: specification from 1962 - October 1974

Old gland nut type: specification pre 1962

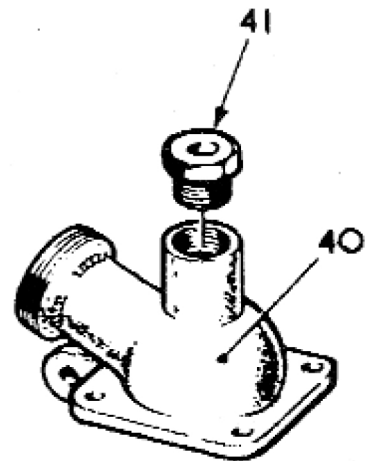
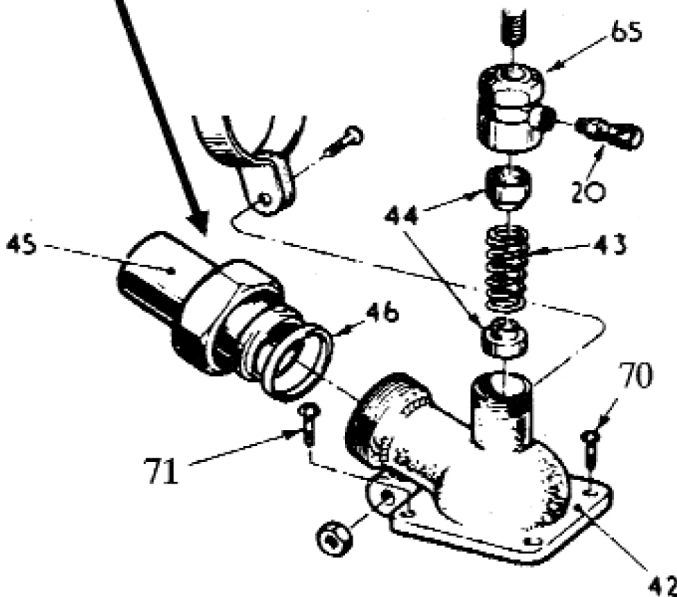

BABY BLAKE & MINOR MODELS

Discharge pump handle assembly

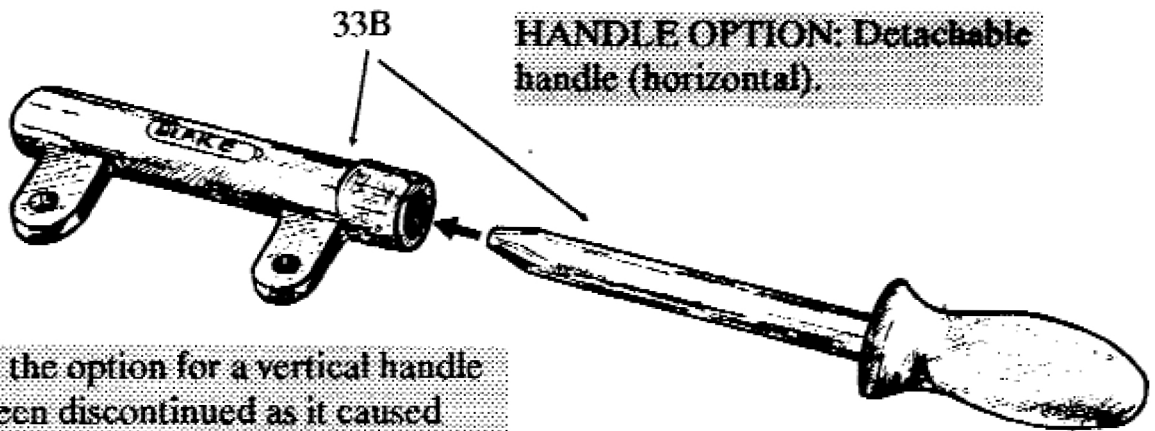

Note: the option for a vertical handle has been discontinued as it caused adverse wear on the pump top seal.

old specification: split pin (current specification: undrilled cross pin (35 or 36) and starlock washer (27A) can be fitted to upgrade old specification).

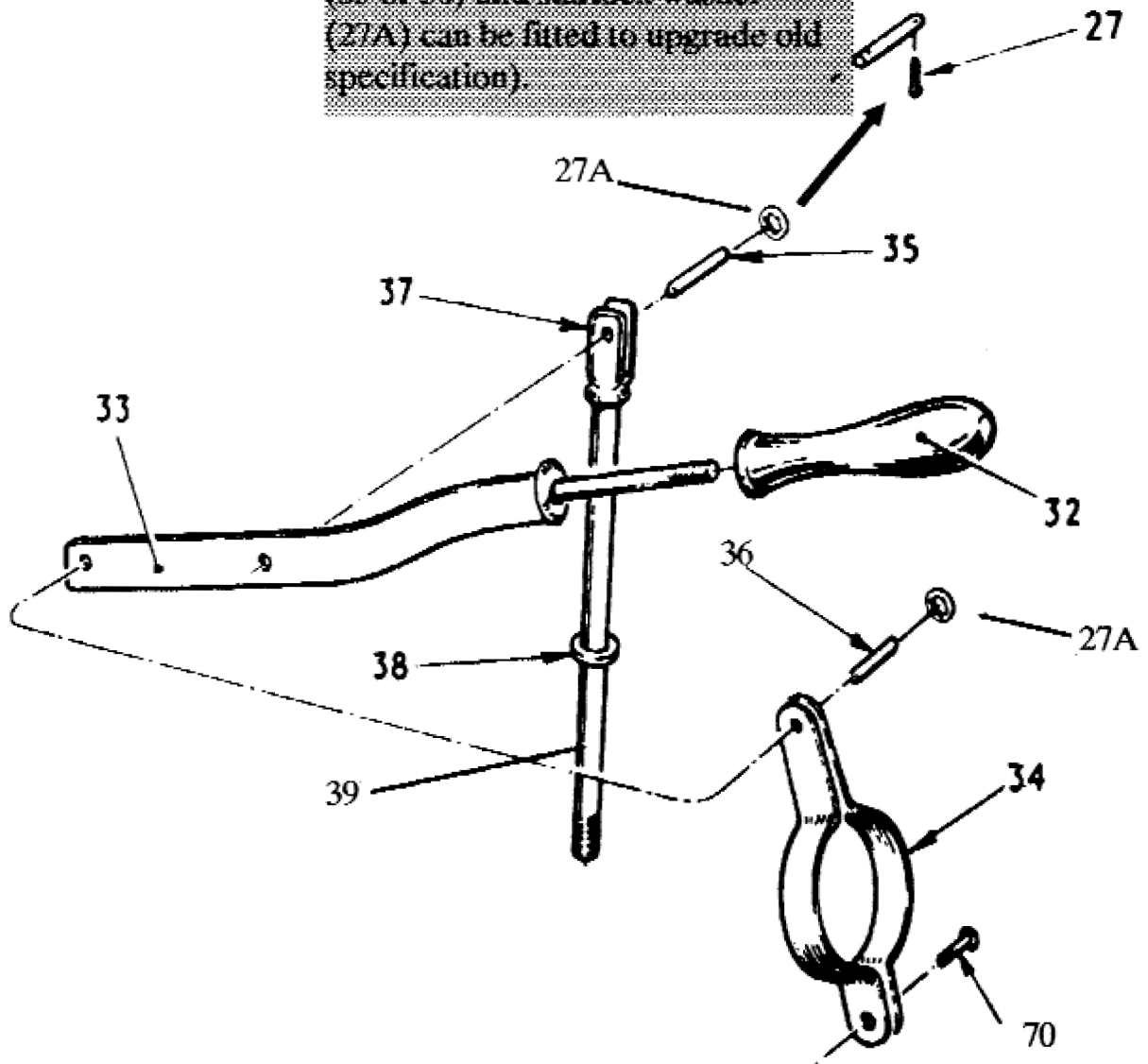

BABY BLAKE & MINOR MODELS

Flushing pump assembly

PAGE 10

SEAL SPECIFICATION

Note: there are 5 specifications including current lip seal type. The current specification can be fitted to upgrade from any previous specification.

old specification bridge piece (23) fixed with pin (27) (current specification uses loctite)

OPTIONS: Pump body. Note: the pump bodies shown here are for right hand toilets (see page 4). Baby left hand pump body (3A) Minor left hand pump body (3MA).

MINOR MODEL

(3M)

OPTION: Extra heavy valve (for installations well below waterline (see section 6.2.1))

MINOR MODEL: Note: for the minor 9 & 4 are joined together as 4M with the longer hose connection (7M) fixed between 12 and 3M.

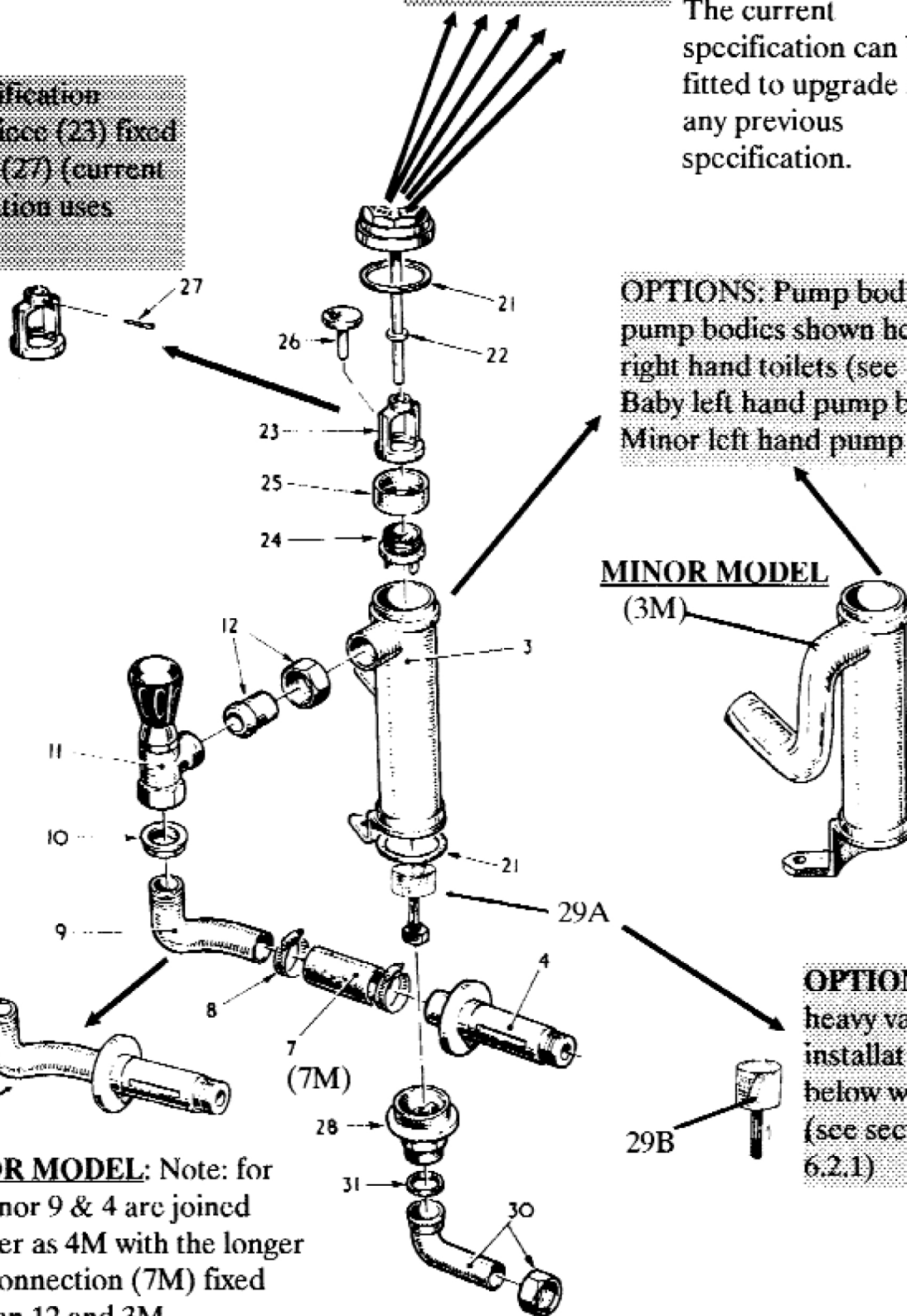

BABY BLAKE & MINOR MODELS

Flushing pump top seal

LIP SEAL TYPE

Current specification (from May 1992)

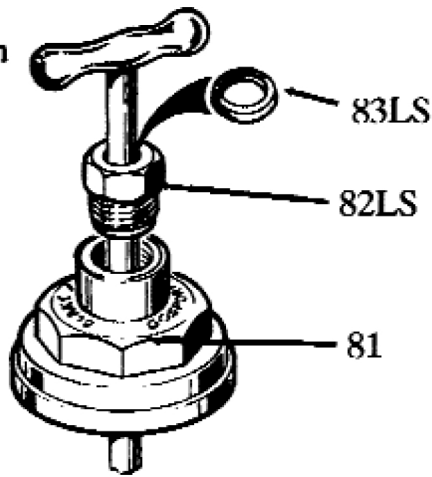

specification from end 1991 - Apr 1992

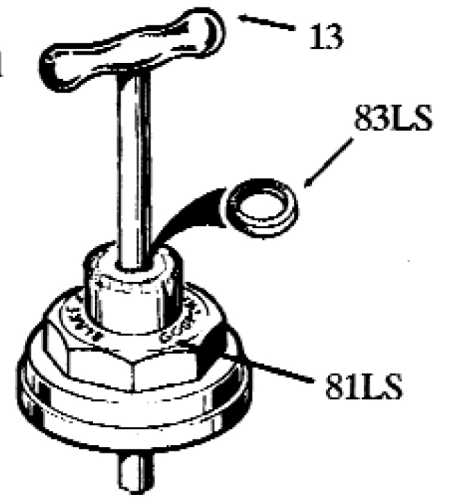

O-RING TYPE

specification from October 1974 - end 1991

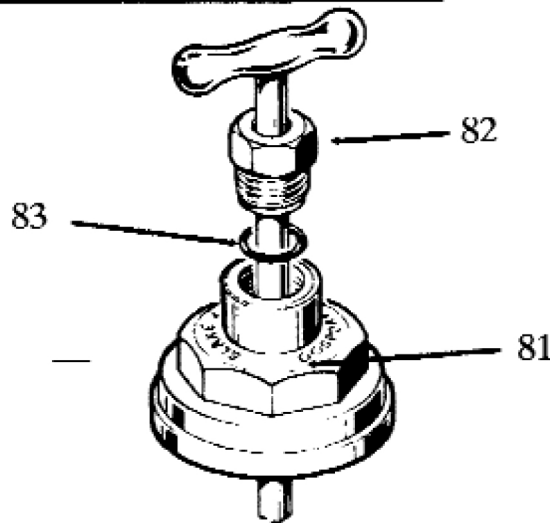

GLAND PACKING TYPE

Self-adjusting gland type: specification from 1962 - October 1974

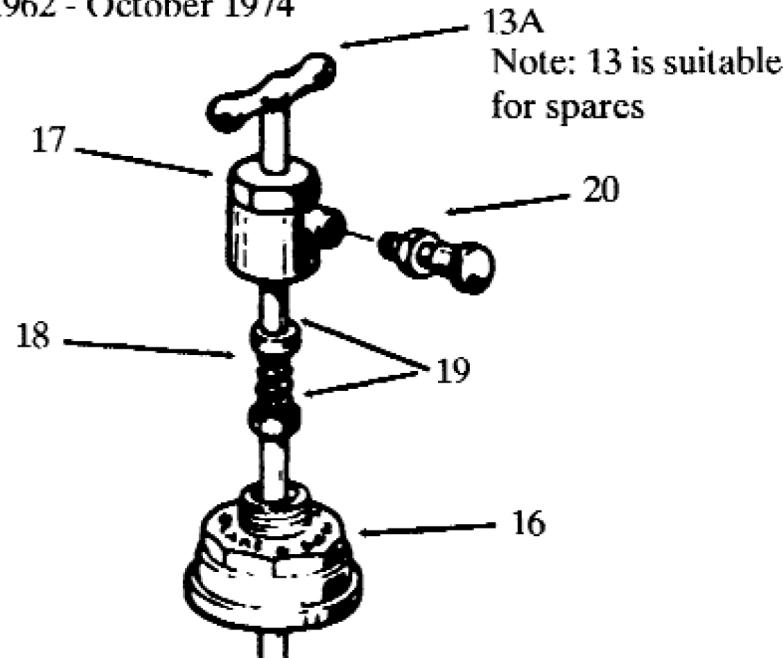

Old gland nut type: specification pre 1962

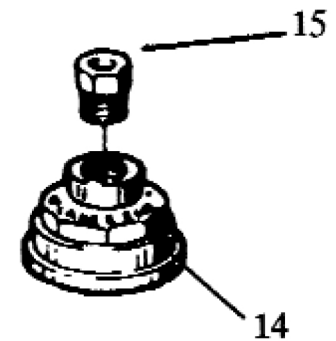

VICTORY MODEL

(DIAGRAMS DETAIL OLD SPECIFICATION COMPONENTS AND OPTIONS)

Note: The diagram on this page details the current specification Victory toilet. The old specification components are detailed on the relevant pages. Options are also detailed, some options have been discontinued and these are specified where relevant.

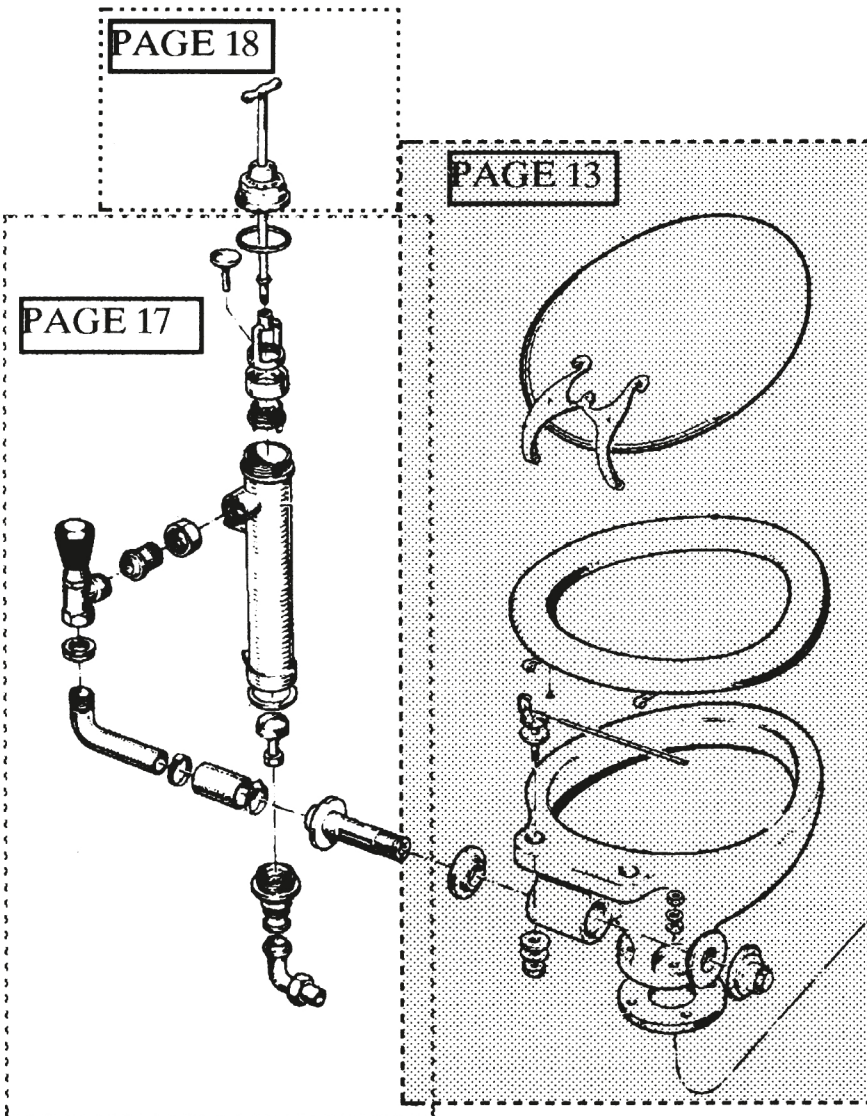
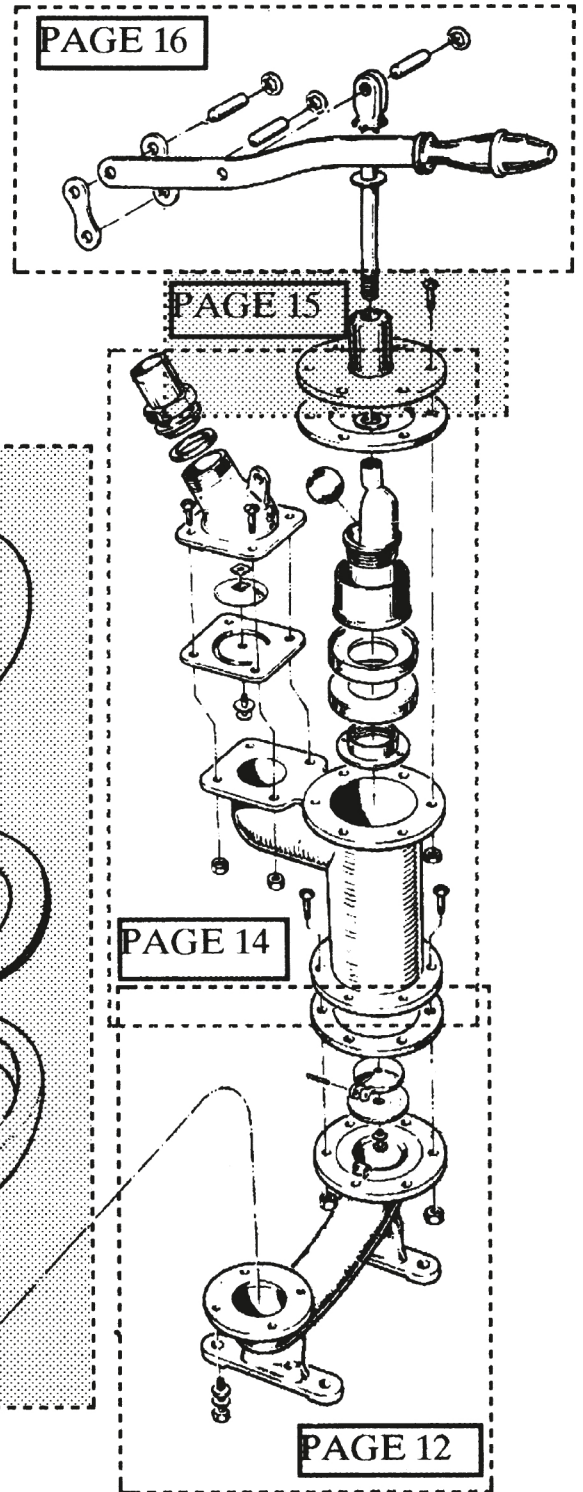

VICTORY MODEL

Toilet Base assembly

DEFINITION OF RIGHT

HAND TOILET OPTION: This is the standard option. Pumps are on the right of the toilet pan (V59A or V59) when facing the front of the toilet.

LEFT HAND OPTION:

Available on request. Pumps are on the left of toilet pan when facing the front of the toilet.

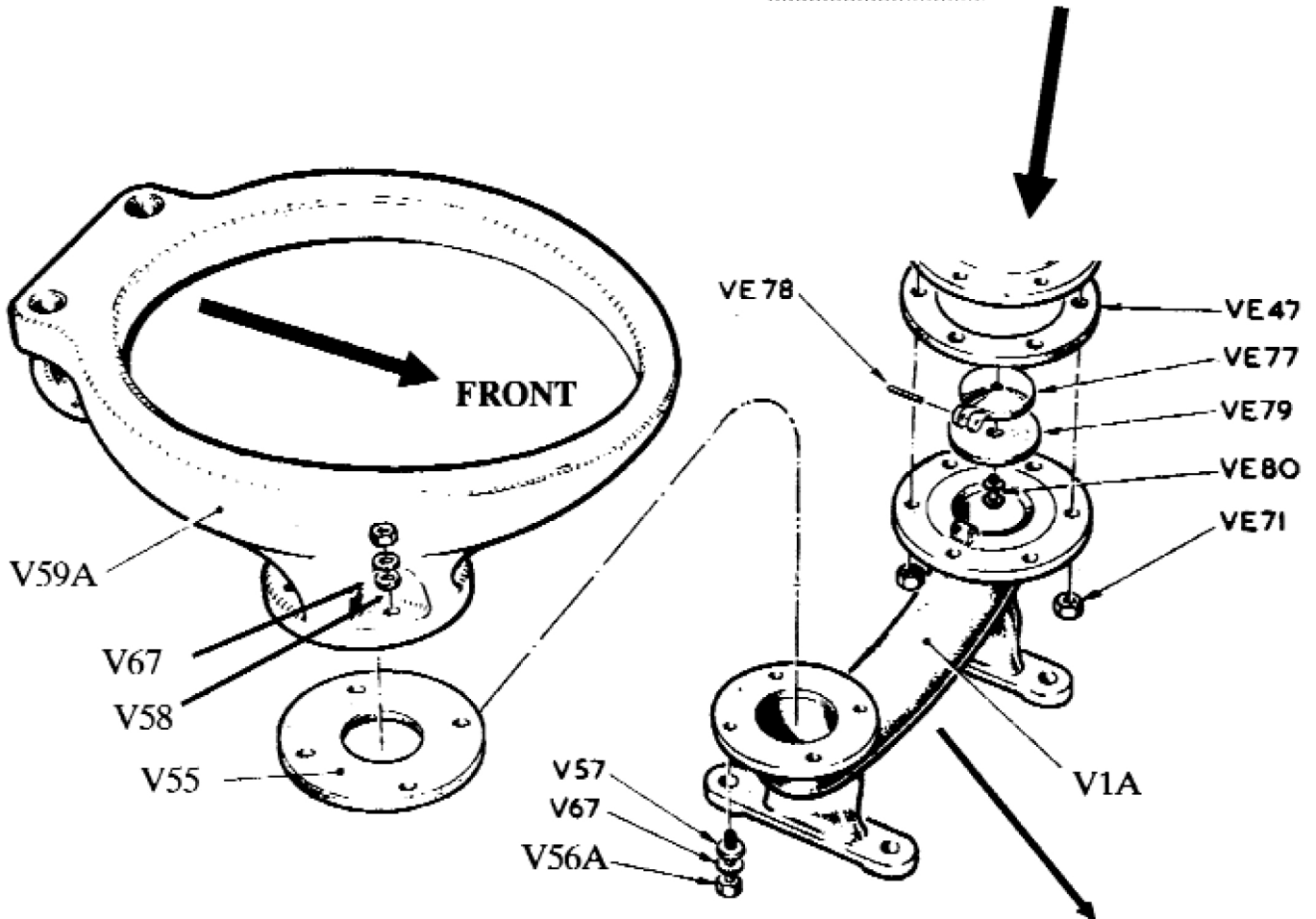

Note: washbasin drain option (V1) now discontinued.

VICTORY MODEL

Toilet pan assembly

Note: the option for a round pan (V59), seat (V64) and lid (V74) has been discontinued.

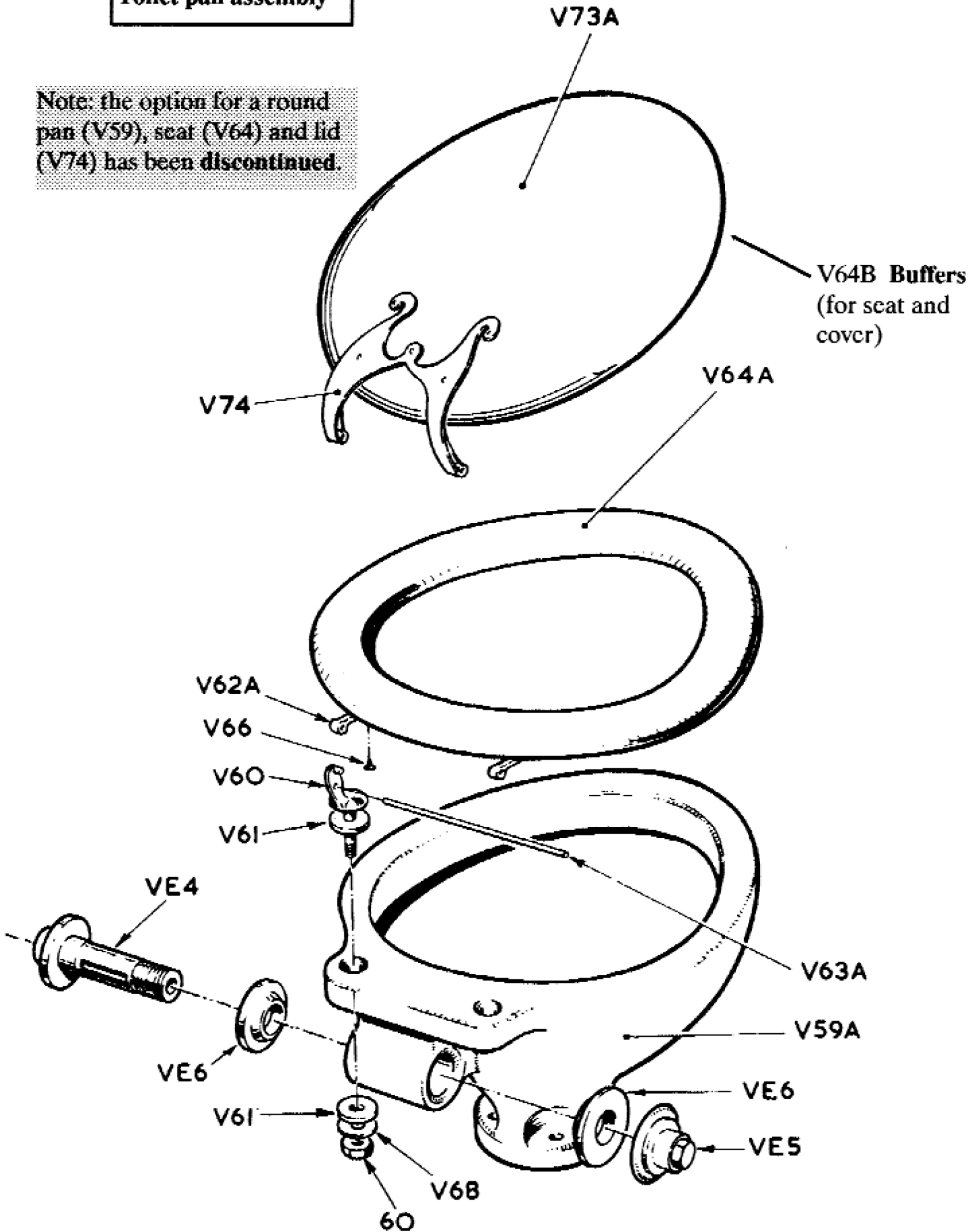

VICTORY MODEL

Discharge pump assembly

OUTLET OPTION:
2" Cap & lining outlet:
(VE39A, VE46A &
VE45A).

**PAGE 15
SEAL
SPECIFICATION**

Note: there are 5 specifications including current lip seal type. The current specification can be fitted to upgrade from any previous specification.

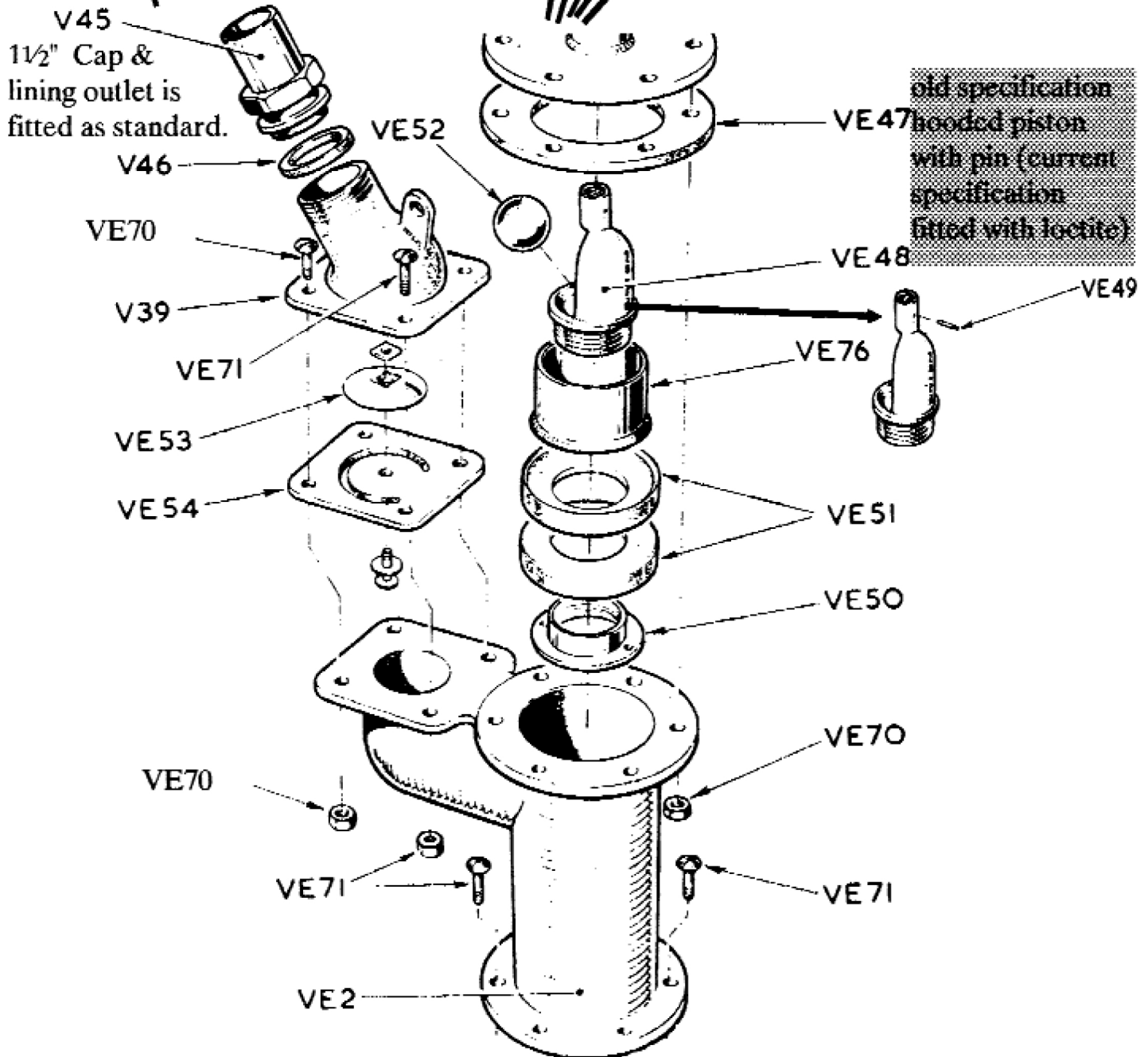

VICTORY MODEL

Discharge pump top seal

Current specification (from May 1992)

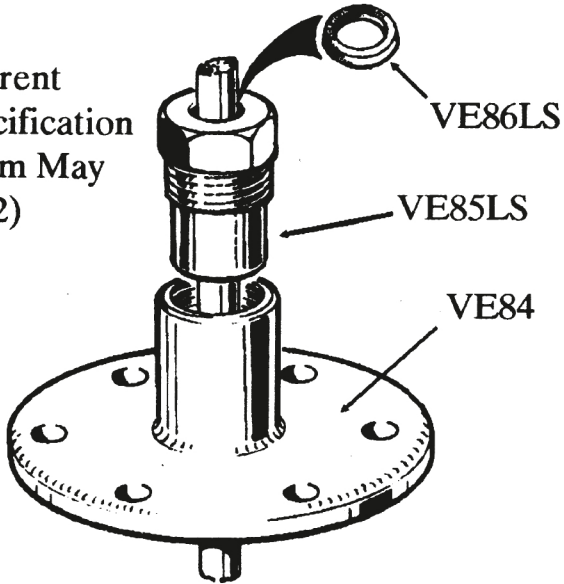

LIP SEAL TYPE

specification from end 1991 - Apr 1992

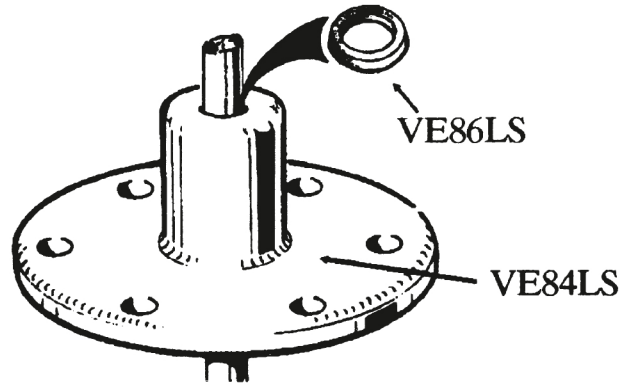

O-RING TYPE

specification from October 1974 - end 1991

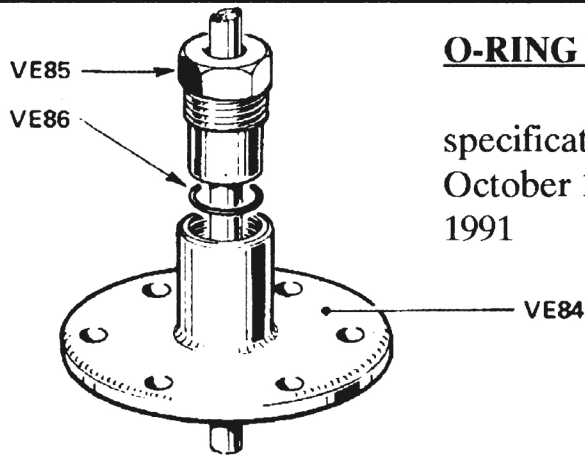

GLAND PACKING TYPE

Self-adjusting gland type: specification from 1962 - October 1974

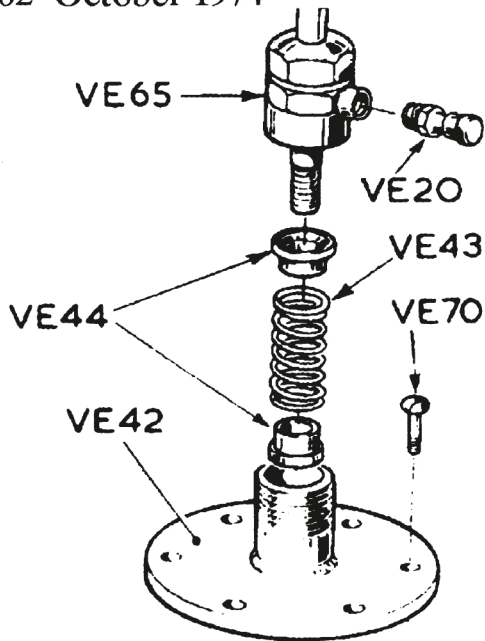

Old gland nut type: specification pre 1962

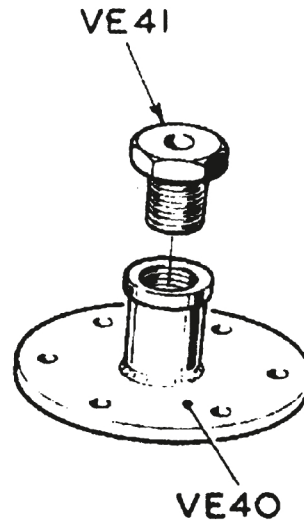

VICTORY MODEL

Discharge pump handle assembly

Note: The options for a Detachable handle or Vertical handle have been discontinued.

old specification: split pin (current specification: undrilled cross pin (35 or 36) and starlock washer (27A) can be fitted to upgrade old specification.

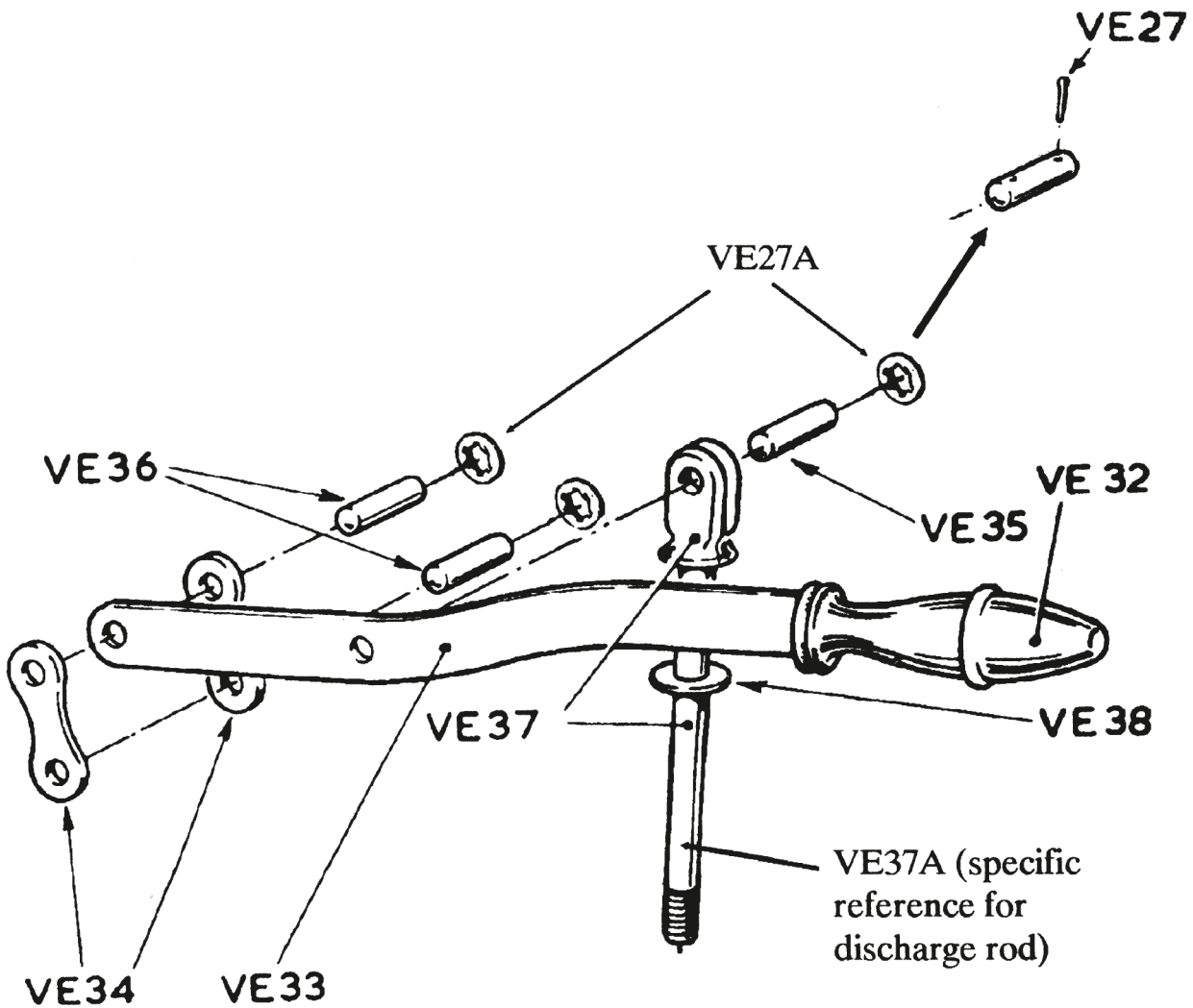

VICTORY MODEL

Flushing pump assembly

PAGE 18

SEAL SPECIFICATION

Note: there are 5 specifications including current lip seal type. The current specification can be fitted to upgrade from any previous specification.

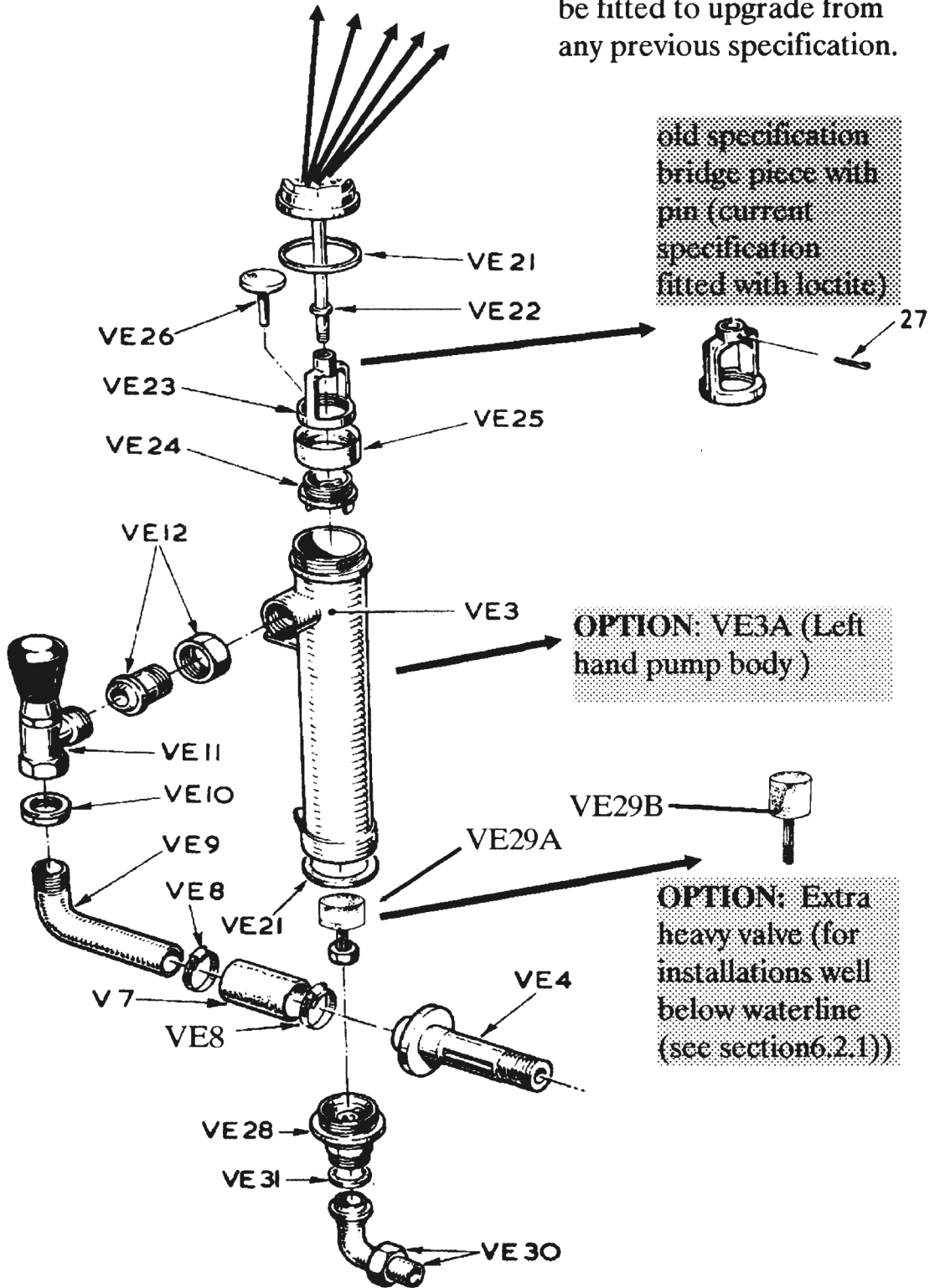

VICTORY MODEL

Flushing pump top seal

LIP SEAL TYPE

Current specification (from May 1992)

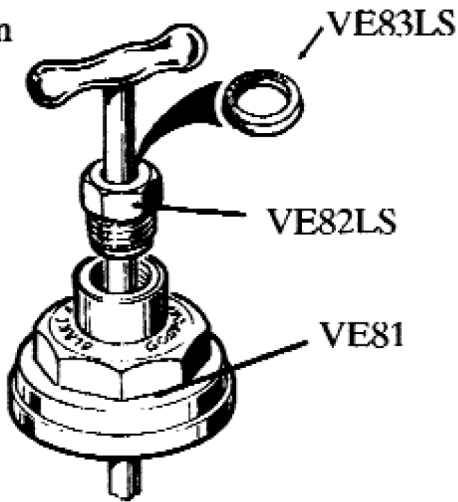

specification from end 1991 - Apr 1992

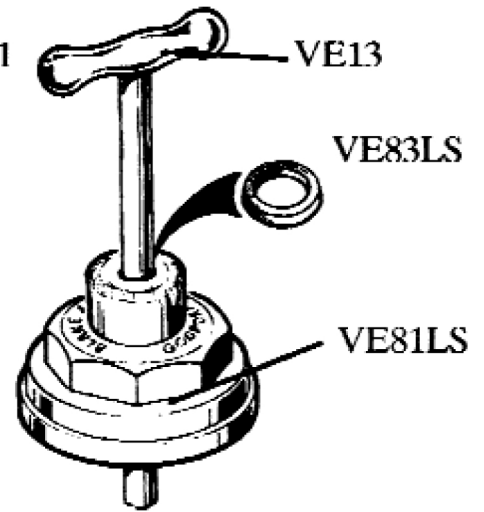

O-RING TYPE

specification from October 1974 - end 1991

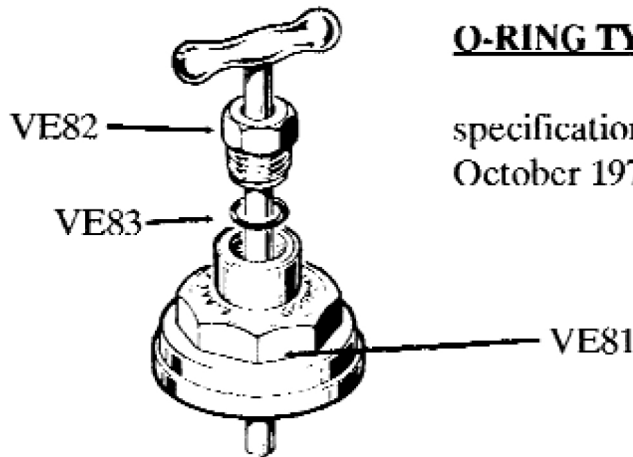

GLAND PACKING TYPE

Self-adjusting gland type: specification from 1962 - October 1974

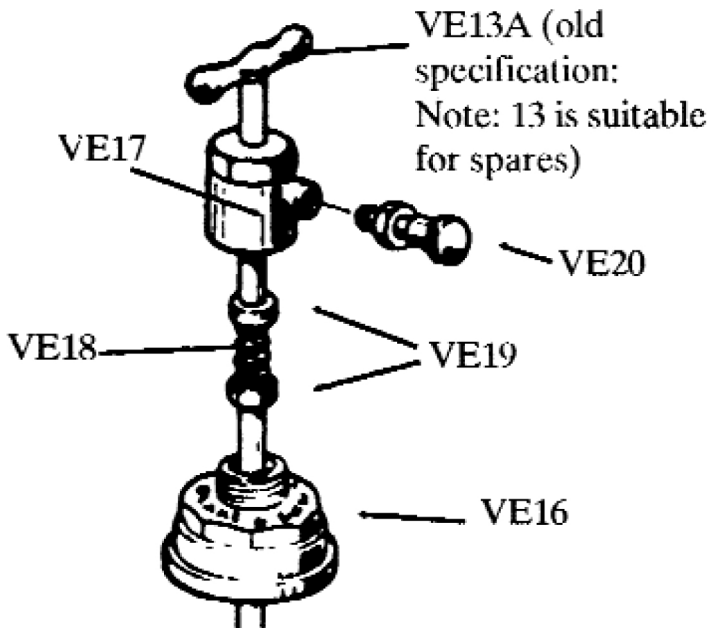

Old gland nut type: specification pre 1962

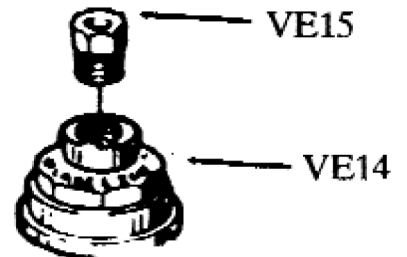

4. SPARE PARTS REFERENCE NUMBERS

A complete range of spare parts, on-board spares kits and spanners for Blakes Marine Toilets are available.

Throughout the text **Diagram numbers** are quoted when referring to toilet components. **Diagram numbers** are also used in **Tables A to D**, in this section, to cross-reference the correct **Spares code** when ordering spares (this is detailed more fully later). Please note that only minimal changes have been made to the **Diagram numbers** quoted on previously published technical literature.

Eclipse model. Despite discontinuing production of the Eclipse model (a larger pan version of the present Victory) some ten years ago, it is expected that these will be in use for at least another 30 to 50 years and thus we have kept the **E** in all **Diagram numbers** for the Victory toilet to denote compatible components. Spares for the Eclipse can thus still be ordered except where the syphon pipe (E1 or E1A), china pan (E59B), pan joint & fixings, hinge assembly and seat & cover components are concerned - these will require a complete conversion to the Victory model.

Diagram numbers for components are detailed on pages 3 to 18. To quickly reference **Diagram numbers** for the Baby or Minor models use the master diagram on page 3; for the Victory model use the master diagram on page 11.

To facilitate the cross-referencing of **Diagram numbers** with the relevant **Spares code** there are four Tables.

TABLE A details **Spares codes** for the latest production, standard version Blakes toilets. The relevant models for each component are coded as **B** for the Baby model; **M** for the Minor model and **V** for the Victory model.

TABLE B lists **Spares codes** for Special items, Cruising spares kits, Spanner kits and Complete assemblies. The individual items that make up the **Cruising spares kits** are shown by highlighting the model codes ie, **B** whenever that particular item is included in the Cruising spares kit for that model. These highlights are shown in **TABLES A** or **B** or **C** as the **Cruising spares kits** are intended to cover all ages (specifications) of the model(s) concerned.

The individual spanners in the **Spanner kits** and what they are used for are detailed on page 31 (**section 7 on Maintenance**).

TABLE C is for ordering spares for a non-standard Blakes toilet. For example, a non-standard Blakes toilet would have a detachable handle (**33B**) - see **page 8**. It also allows ordering of options where the owner wishes to change the specification of the toilet eg. installing an extra heavy lower valve (**29B** or **VE29B**) to allow for an installation well below the waterline (see section 5.2.1).









TABLE D details the Spares code for old specification components ie. older types of toilets, where current production models use different design components. If exact replacement components are not available **TABLE D** indicates the **Diagram numbers** of components required for replacement of a complete sub-assembly.

Please note that when ordering spares for old specification toilets please quote the **Diagram number** of the part being replaced as this will help us to ensure you have ordered correctly. In some cases factory tested assemblies are required for replacement. As indicated in **TABLE D** old specification components do not always have the current specification component as a direct replacement and in many cases require a replacement at sub assembly level.

Chillington Marine Limited, the manufacturer of Blakes Marine Toilets, supply spare parts for their models direct and through the marine trade (chandlers and boat builders). Overseas, spare parts are supplied through appointed agents. If you require spare parts, on-board spares kits or help in locating a local chandler or agent, wherever you are in the world, please contact us direct. **Our address and telephone number can be found on the back of this leaflet.**

**TABLE A: SPARES FOR CURRENT SPECIFICATION TOILETS -
BABY, MINOR AND VICTORY MODELS**

KEY:  = Components included in Extended Cruising Spares kit (see TABLE B)

| DIAGRAM No: | MODEL | SPARES CODE: | DESCRIPTION | No OFF |
|-------------|---|--------------|------------------------------------|--------|
| 1A | B | TBB7025 | SYPHON PIPE (STANDARD) | 1 |
| 1MA | M | TBM7755 | SYPHON PIPE (STANDARD) | 1 |
| V1A | V | TBV7905 | SYPHON PIPE (STANDARD) | 1 |
| 2 | B M | TBB7505 | DISCHARGE CYLINDER | 1 |
| VE2 | V | TBV7910 | DISCHARGE CYLINDER | 1 |
| 3 | B | TBB7030 | FLUSHING PUMP BODY (RIGHT HAND) | 1 |
| 3M | M | TBM7760 | FLUSHING PUMP BODY (RIGHT HAND) | 1 |
| VE3 | V | TBV7915 | FLUSHING PUMP BODY (RIGHT HAND) | 1 |
| 4 | B | TBB7510 | BACK CONNECTION | 1 |
| 4M | M | TBM7041 | BACK PIPE/CONNECTION | 1 |
| 5 | B M V | TBB7106 | HEXAGON CAP NUT - CHROME | 1 |
| 6 |  M V | TBB7300 | WASHER [BACK CONNECTION] | 2 |
| 7 | B  V | TBB7010 | HOSE CONNECTION (SHORT) | 1 |
| 7M |  M | TBM7705 | HOSE CONNECTION (LONG) | 1 |
| 8 |  M V | TBB7335 | HOSE CLIP - STAINLESS STEEL | 2 |
| 9 | B | TBB7040 | BACK PIPE | 1 |
| VE9 | V | TBV7925 | BACK PIPE | 1 |
| 10 | B M V | TBB7646 | BACK NUT (3/4") | 1 |
| 11/12 | B M V | TBB7115 | SAFETY CONTROL VALVE - CHROME | 1 |
| 13 | B M | TBB7126 | TEE HANDLE/SPINDLE [FLUSHING PUMP] | 1 |
| VE13 | V | TBV7996 | TEE HANDLE/SPINDLE [FLUSHING PUMP] | 1 |
| 21 |  M V | *TBB7346 | PAIR OF WASHERS - COPPER/ASBESTOS | 1 |
| 22 |  M V | TBB7350 | WASHER [FLUSHING PUMP SPINDLE] | 1 |
| 23 | B M V | TBB7140 | BRIDGE PIECE | 1 |
| 24 | B M V | TBB7515 | VALVE PLUG | 1 |
| 25 |  M V | TBB7355 | BUCKET WASHER [FLUSHING PUMP] | 1 |
| 26 | B M V | TBB7520 | SMALL VALVE | 1 |
| 27A | B M V | TBV7811 | STARLOCK WASHER [CROSS PINS] | 4:6 |
| 28 | B M V | TBB7146 | LOWER VALVE HOUSING | 1 |
| 29A | B M V | *TBB7152 | LOWER VALVE & NUT (HEAVY) | 1 |
| 30 | B M V | *TBB7157 | BENT CAP AND LINING FOR INLET | 1 |
| 31 |  M V | TBB7360 | WASHER - LEATHER (1") | 1 |
| 32 | B M V | TBB7165 | HANDLE GRIP | 1 |
| 33 | B M | TBB7171 | HORIZONTAL HANDLE | 1 |
| VE33 | V | TBV7951 | HORIZONTAL HANDLE | 1 |
| 34 | B M | TBB7175 | HANDLE STIRRUP (OR LINK) | 1 |
| VE34 | V | TBV7816 | HANDLE LINK | 2 |
| 35 | B M V | *TBV7955 | CROSS PIN | 1:2 |
| 36 | B M | *TBB0993A | CROSS PIN [HANDLE STIRRUP] | 1 |
| VE35 | V | *TBV7956 | CROSS PIN [DOUBLE LUG] | 1 |
| 37 | B M | TBB7536 | DOUBLE LUG | 1 |
| VE37 | V | *TBV7967 | DISCHARGE ROD & DOUBLE LUG | 1 |
| VE37A | V | TBV7960 | DISCHARGE ROD | 1 |

| DIAGRAM No: | MODEL | SPARES CODE: | DESCRIPTION | No OFF | |
|-------------|--------|--------------|-------------|-------------------------------------|-----|
| 38 | | B M | TBB7365 | WASHER - LEATHER (1/2") | 1 |
| | VE38 | | TBV7875 | WASHER - LEATHER (5/8") | 1 |
| 39 | | B M | TBB7185 | DISCHARGE ROD | 1 |
| | V39 | | TBV7935 | OUTLET - CAP & LINING (1.1/2" BSP) | 1 |
| | V45 | | *TBB7617 | CAP & LINING (1.1/2") FOR OUTLET | 1 |
| | V46 | | TBB7370 | WASHER - LEATHER (1.1/2") | 1 |
| 47 | | B M | TBB7375 | JOINT [DISCHARGE CYLINDER] | 1 |
| | VE47 | | TBV7880 | JOINT [DISCHARGE CYLINDER] | 2 |
| 48 | VE48 | B M V | TBB7225 | HOODED PISTON | 1 |
| 50 | | B M | TBB7205 | PISTON LOCKING RING | 1 |
| | VE50 | | TBV7970 | PISTON LOCKING RING | 1 |
| 51 | | B M | TBB7380 | BUCKET WASHER [DISCHARGE] | 2 |
| | VE51 | | TBV7885 | BUCKET WASHER [DISCHARGE] | 2 |
| 52 | VE52 | B M V | TBB7385 | CENTRE WEIGHTED RUBBER BALL | 1 |
| | VE53 | | *TBV7426 | LEAD WEIGHT AND SCREW | 1 |
| | VE54 | | TBV7890 | TOP CLACK VALVE [DISCHARGE PUMP] | 1 |
| 55 | V55 | B M V | TBB7390 | JOINT - PAN BASE | 1 |
| 56A | V56A | B M V | *TBB7211 | BOLT & NUT (6MM) [CHINA PAN] | 1 |
| 57 | V57 | B M V | TBB7395 | WASHER - FIBRE [PAN BOLT] | 4 |
| 58 | V58 | B M V | TBB7400 | WASHER - RUBBER [PAN BOLT] | 4 |
| 59A | V59A | B M V | TBB7220 | OVAL CHINA PAN | 1 |
| 60 | V60 | B M V | *TBB7232 | PILLAR AND NUTS [SEAT & COVER] | 2 |
| 61 | V61 | B M V | TBB7405 | WASHER - RUBBER [SEAT PILLAR] | 4 |
| 62A | V62A | B M V | TBB7541 | HINGE BRACKET [SEAT] | 1 |
| 63A | V63A | B M V | *TBB7626 | HINGE PIN [SEAT AND COVER HINGE] | 1 |
| 64A | V64A | B M V | *TBB7241 | OVAL SEAT AND BUFFERS | 1 |
| 64B | V64B | B M V | *TBB7290 | BUFFER & SCREW [SEAT or COVER] | 12 |
| 66 | V66 | B M V | TBB7250 | SELF-TAPPING SCREW (COUNTERSUNK) | 11 |
| 67 | V67 | B M V | TBB7255 | WASHER - PLAIN (1/4") [PAN BOLT] | 8 |
| 68 | V68 | B M V | TBB7261 | WASHER (3/82) [SEAT PILLAR] | 2 |
| 70 | VE70 | B M V | *TBB7277 | ASSEMBLY BOLT & NUT (3/8" x 1.1/8") | 7:9 |
| 71 | VE71 | B M V | *TBV7847 | ASSEMBLY BOLT & NUT (3/8" x 1.3/8") | 2:7 |
| 73A | V73A | B M V | *TBB7286 | OVAL COVER AND BUFFERS | 1 |
| 74 | V74 | B M V | TBB7546 | HINGE BRACKET [COVER] | 1 |
| 76ALS | | B M | TBB7555 | PUMP TOP (HOSE/C) [DISCHARGE PUMP] | 1 |
| | VE76 | | TBV7850 | CYLINDER VALVE OR COMBING RING | 1 |
| | VE77 | | TBV7945 | LOWER CLACK VALVE [DISCHARGE] | 1 |
| 78LS | | B M | TBB7411 | LIP SEAL (1/2") [DISCHARGE PUMP] | 1 |
| | VE78 | | *TBV7985 | HINGE PIN [LOWER CLACK VALVE] | 1 |
| | VE79 | | TBV7895 | VALVE [LOWER CLACK VALVE] | 1 |
| | VE80 | | *TBV7856 | SCREW & WASHER (1/4") [LOWER CLACK] | 1 |
| 81LS | VE81LS | B M V | TBB7296 | PUMP TOP [FLUSHING PUMP] | 1 |
| 83LS | VE83LS | B M V | TBB7416 | LIP SEAL (3/8") [FLUSHING PUMP] | 1 |
| | VE84LS | | TBV7870 | PUMP TOP [DISCHARGE PUMP] | 1 |
| | VE86LS | | TBV7901 | LIP SEAL (5/8") [DISCHARGE PUMP] | 1 |
| 84 | | B M | TBB7420 | JOINT/VALVE [CLACK VALVE] | 1 |
| 84-87 | | B M | *TBB7431 | CLACK VALVE ASSEMBLY [DISCHARGE] | 1 |

TABLE B: SPECIAL SPARES NUMBERS

| MODEL | SPARES CODE | DESCRIPTION |
|--|-------------|--|
| B M V | TBB7111 | PLASTIC KNOB [SAFETY CONTROL VALVE (VE)11] |
| B M | *TBB7187 | DISCHARGE ROD & DOUBLE LUG (37 & 39) |
| B M V | TBB7271 | NUT (3/8") [3/8" (WHIT.) BOLTS] |
| B M V | *TBB7252 | COMPLETE HINGE ASSEMBLY INCL. PILLARS |
| B M V | TBB7997 | DOME NUT [SYPHON PIPE BASE] |
| B M V | *TBB7288 | OVAL SEAT & COVER & HINGE ASSEMBLY |
| B M V | TBB7430 | SPACING WASHER [T-HANDLE (VE)13] |
| EXTENDED CRUISING SPARES KITS | | |
| B M | *TBB0782 | COMPLETE SET OF PERISHABLE SPARES |
| V | *TBV0881 | The components included in these kits are shown in Tables A,C & D by referring to the KEY. They cover all specification toilets and possible options e.g. 1.1/2" leather washer for toilets with Cap & lining outlets (see page 7). Note that the hose connection (7) for Baby is cut from 7M. |
| SPANNER KITS FOR MAINTENANCE OF TOILETS | | |
| B M | *EST3111 | COMPLETE SET OF SPANNERS. |
| V | *EST3222 | The Blakes toilets are designed to last and spanners that cater for all situations are included in these kits (see page 31) |
| COMPLETE ASSEMBLIES (LIP SEAL TYPE) | | |
| | | A popular option when overhauling Blakes toilets that are many decades old is to replace complete assemblies. The advantages in doing this are: factory tested assemblies and the latest specification pump top seals. |
| B | *TBB7031 | FLUSHING PUMP (RIGHT HAND) |
| B | *TBB7036 | FLUSHING PUMP (LEFT HAND) |
| B | *TBB7506 | DISCHARGE PUMP (HOSE CONNECTION) |
| B | *TBB7508 | DISCHARGE PUMP (CAP & LINING) |
| B M | *TBB7556 | PUMP TOP ASSEMBLY (HOSE/CONN) [DISCHARGE] |
| B M | *TBB7551 | PUMP TOP ASSEMBLY (CAP/LINING) [DISCHARGE] |
| B M V | *TBB7298 | PUMP TOP ASSEMBLY [FLUSHING] |
| M | *TBM7761 | FLUSHING PUMP (RIGHT HAND) |
| M | *TBM7766 | FLUSHING PUMP (LEFT HAND) |
| M | *TBM7506 | DISCHARGE PUMP (HOSE CONNECTION) |
| M | *TBM7508 | DISCHARGE PUMP (CAP & LINING) |
| V | *TBV7916 | FLUSHING PUMP (RIGHT HAND) |
| V | *TBV7917 | FLUSHING PUMP (LEFT HAND) |
| V | *TBV7911 | DISCHARGE PUMP (CAP & LINING 1.1/2" OUTLET) |
| V | *TBV7912 | DISCHARGE PUMP (CAP & LINING 2" OUTLET) |
| V | *TBV7871 | PUMP TOP (UPGRADE) (DISCHARGE) |

TABLE C: OPTIONS OR SPARES FOR OPTIONS

KEY: = Components included in Extended Cruising Spares kit (see TABLE B)

| DIAGRAM No: | MODEL | SPARES CODE | DESCRIPTION |
|-------------|-------|-------------|---|
| 1 | B | TBB7045 | SYPHON PIPE (WASHBASIN DRAIN) |
| 3A | B | TBB7035 | FLUSHING PUMP BODY (LEFT HAND) |
| 3MA | M | TBM7765 | FLUSHING PUMP BODY (LEFT HAND) |
| VE3A | V | TBV7920 | FLUSHING PUMP BODY (LEFT HAND) |
| 29B | B M V | *TBB7153 | LOWER VALVE & NUT (EXTRA HEAVY) |
| 33B | B M | *TBB7964 | DETACHABLE HANDLE ASSEMBLY |
| 45 | B M | *TBB7617 | CAP AND LINING (1.1/2") [DISCH. PUMP TOP] |
| 46 | B M | TBB7370 | WASHER - LEATHER (1.1/2") |
| VE45A | V | *TBV7837 | CAP AND LINING (2") [DISCH. PUMP TOP] |
| VE46A | V | SCX6989 | WASHER - LEATHER (2") |
| 64A | B M V | *TBB7241M | MAHOGANY OVAL SEAT AND BUFFERS |
| 73A | B M V | *TBB7286M | MAHOGANY OVAL COVER AND BUFFERS |
| 75 | B M V | *TBB7020 | BENT CAP AND LINING (WASHBASIN DRAIN) |
| 76 | B M | TBB7550 | PUMP TOP (CAP/LIN 1.1/2") [DISCHARGE] |

NOTES

TABLE D: SPARES/UPGRADE FOR DISCONTINUED (OLD) SPECIFICATIONS

KEY: = Components included in Extended Cruising Spares Kit (see TABLE B)

| DIAGRAM No: (INCLUDES OLD No's) | DESCRIPTION OF ITEMS THAT ARE EITHER: (a) STILL AVAILABLE or, (b) REQUIRE AN UPGRADE | (a) SPARES CODE | (b) UPGRADE TO: |
|--|---|---|---|
| V1 E7A 13A VE13A | SYPHON PIPE (WASHBASIN DRAIN) HOSE CONNECTION (ECLIPSE MODEL) T HANDLE [FLUSHING PUMP] T HANDLE [FLUSHING PUMP] | On request | V1A 13 V13 |
| 14,15 16-20 VE14,VE15 VE16-20 | FLUSHING PUMP TOP SEAL (GLAND PACKING) FLUSHING PUMP TOP SEAL (SELF-ADJUSTING GLAND PACKING) ALL OR ANY PART OF: (EXCEPT: (VE)18,(VE)19,(VE)72) | |] (VE)81LS,] (VE)83LS]] |
| 18 19 27 33A VE18 VE19 VE27 | GLAND SPRING - BRONZE (3/8") [FLUSHING] GLAND SPRING COLLAR [FLUSHING PUMP] SPLIT PIN VERTICAL HANDLE | TBB7130 TBB7135 TBB7810 | 33 |
| VE33A,VE34A & VE36A V39B,VE39C | VERTICAL HANDLE ASSEMBLY: ALL OR PART OF PUMP TOP FOR VERTICAL HANDLE [DISCHARGE] | |] V39,VE33,] VE34, &] VE36 |
| 40,41 VE40,VE41 | DISCHARGE PUMP SEAL (GLAND PACKING) DISCHARGE PUMP SEAL (GLAND PACKING) | | 76ALS,78LS VE84LS,VE86LS |
| 42,20,43, 44 & 65 | DISCHARGE PUMP TOP SEAL (SELF-ADJUSTING GLAND PACKING) ALL OR ANY PART OF: (EXCEPT: 43,44,72) | |] 76ALS,] 76ALS] |
| 43 44 | GLAND SPRING - BRONZE (1/2") [DISCHARGE] GLAND SPRING COLLAR (1/2") [DISCHARGE] | TBB7190 TBB7195 | |
| VE42,VE20, VE43,VE44, & VE65 | DISCHARGE PUMP TOP SEAL (SELF-ADJUSTING GLAND PACKING) ALL OR ANY PART OF: (EXCEPT: VE43,VE44,VE72) | |] VE84LS,] VE84LS] |
| VE43 VE44 49 VE49 | GLAND SPRING - BRONZE (5/8") [DISCHARGE] GLAND SPRING COLLAR (5/8") [DISCHARGE] SECURING PIN - HOODED PISTON | TBV7820 TBV7825 On request | (or use Loctite) |
| 53,54 | CLACK VALVE: OLD SPECIFICATION | |] 84,85,] 86,87 |
| 56 V56 | BOLT & NUT (1/4") [PAN BASE] | | (V)56A |
| 59 V59 | ROUND CHINA PAN | |] (V)59A,(V)64A,] & (V)73A |
| 64,73 69 72 76A 76 77(LS) 78 81 82(LS) 83 VE81 VE82(LS) VE83 VE84 VE85(LS) VE86 | ROUND SEAT OR COVER BOLT & NUT (3/8" x 7/8" WHIT.) GLAND PACKING (FLUSHING & DISCHARGE) PUMP TOP (HOSE/CONN) [DISCHARGE] PUMP TOP (CAP/LINING) [DISCHARGE] GLAND NUT [DISCHARGE] O-RING (1/2") [DISCHARGE] PUMP TOP [FLUSHING PUMP] GLAND NUT [FLUSHING] O-RING (3/8") [FLUSHING] PUMP TOP [DISCHARGE PUMP] GLAND NUT [DISCHARGE] O-RING (5/8") [DISCHARGE] | TBB7640 TBB7550 TBB7410 TBB7415 TBV7900 | (V)64A,(V)73A (VE)70 76ALS,78LS 77LS (VE)81LS,(VE)83LS (VE)82LS VE84LS,VE86LS VE85LS |

5. INSTALLING YOUR MARINE TOILET

5.1. SITING AND INSTALLING THE SEACOCKS

Having chosen the type of inlet and discharge seacocks required for your particular needs, they should be mounted in the hull. We recommend Blakes Seacocks for use with our marine toilets. The inlet is 19mm (3/4") and the outlet is 38mm (1 1/2"). The inlet seacock should be about 460mm (18") below the water line and forward of the discharge seacock. On a sailing vessel, the distance below the water line may have to be more to allow for heeling. The discharge seacock should also be below the water line but need not be as deep as the inlet. The location of both seacocks should be convenient for attaching piping to and from the toilet and easily accessible for turning off. Ensure that they are positioned to accept the hoses before drilling the holes to accept the fixing bolts.

Fitting the seacocks to the boat.

For fibre-glass boats we recommend the fitting of a wooden pad, bonded to the hull, slightly greater in diameter than the seacock flange and 13mm to 19mm (1/2" to 3/4")

thick. To ensure water-tight joints on G.R.P.(Glass Reinforced Plastic) hulls, a small amount of underwater sealing compound should be put between the inside skin and this pad and also under the seacock flange.

For wooden hulls, ensure that drilling is carried out in the centre of a hull plank.

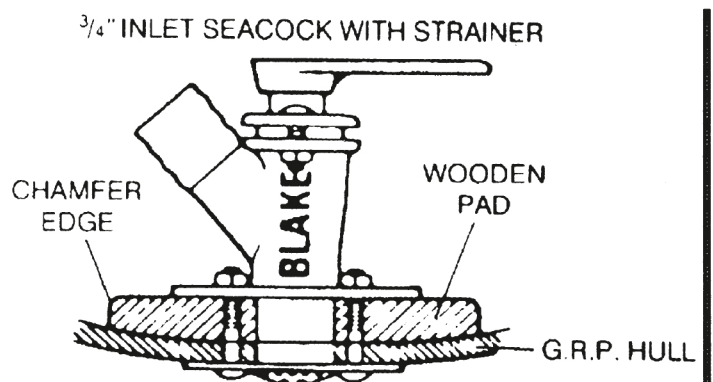

For steel hulls, the sea-cocks must **not** under any circumstances be bolted directly onto the hull. They should be isolated with a gasket and studded with stainless steel fittings to a pad welded to the hull. This is to prevent electrolytic action.

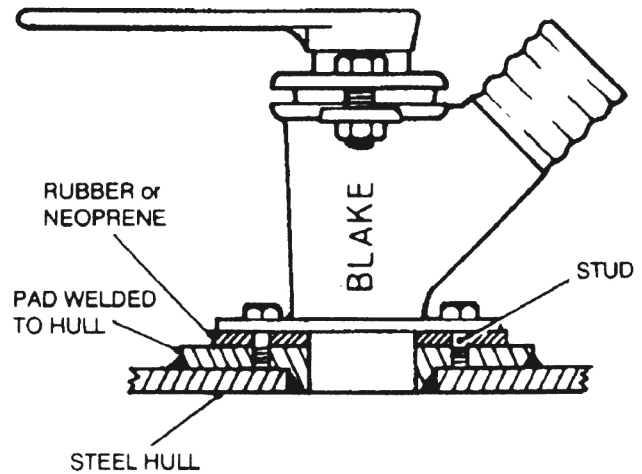

For aluminium (alloy) hulls, special aluminium sea-cocks should be used. Plastic sea-cocks are often used as an alternative.

Sea-cock spigots should be cut off to suit the outside of the hull. The inlet sea-cock should be flush with the outside of the hull and a strainer fitted. Similarly the discharge sea-cock should protrude to enable it to take the discharge plate.

5.2. SITING AND INSTALLING THE TOILET (utilising current modifications in clack valve)

5.2.1 Siting below the waterline

The toilet is supplied as standard with a heavy lower valve (29A or VE29A) which is suitable for installations mounted up to 510mm (20") below the waterline. There is an option for an extra heavy lower valve (29B or VE29B) which allows the installation to be mounted up to 1220mm (48") below the waterline. Please note that it is vital to ensure that the wheel control valve is turned off after use.

5.2.2 Siting above the waterline

Blakes toilets have been sited in installations well above the waterline. It is strongly recommended however that installations above 1.9m (6') have a one-way valve located in the inlet pipe just below the flushing pump (no loop is required in the inlet pipe) so that the pump maintains its prime.

5.2.3 General

The base of the syphon pipe (1A or 1MA or V1A) should be mounted on a hardwood platform approximately 32mm (1¼") thick. A template should be used for drilling the holes necessary in the platform.

Securing bolts 10mm (3⁄8") should be passed from the platform to pick up the four holes in the base, capped with dome nuts and tightened securely (dome nuts are available as accessories - see **Section 4, TABLE B**).

For safety reasons, the discharge pipe should be taken up vertically high enough to always be above the water line (see below for installations incorporating a holding tank) - **MAKE SURE YOU ALLOW FOR THE WATERLINE RISING WHEN THE BOATS HEELS** - and then through a smooth bend down to the discharge seacock. This loop enables the toilet to work better by exerting a slight back pressure on the valves.

It is not necessary for the inlet pipe to be connected to the inlet seacock with a similar loop **if the safety control valve (11 or VE11) is always turned off after each use of the flushing pump** (see section 6).

5.2.4 Installations incorporating a holding tank

The Blake toilets are perfectly suitable for use with holding tanks. It is necessary however, to ensure that the loop of the discharge hose is taken in a loop above the top of the holding tank to prevent syphoning back of the contents of the holding tank (ensure that the loop still allows for the boat heeling).

5.2.5 Installations with a washbasin (Syphon pipe 1 or V1)

Unless a separate seacock is used, the basin can be pumped out through the toilet by means of a connection in the syphon pipe. Note that this is a special option and must be specified. Washbasins should only be connected to the toilet if fitted on the same side of the vessel as the toilet.

6. OPERATING YOUR MARINE TOILET

BEFORE USE

Turn Safety control valve (11 or VE11) anti-clockwise to open.

Pump flushing water into the pan (59A or V59A) - using handle 13 or VE13 - up to the line on the pan.

AFTER USE

Discharge using handle 33 or VE33.

Flush the pan (59A or V59A) using handle 13 or VE13.

Discharge again.

Flush again thoroughly. Finally discharge remaining water in pan to leave pan empty.

Close Safety control valve (11 or VE11) by turning clockwise.

IMPORTANT

Always pump the system completely clear of waste. It is necessary to do this thoroughly to ensure the discharge pipe and outlet seacock are also clear of waste.

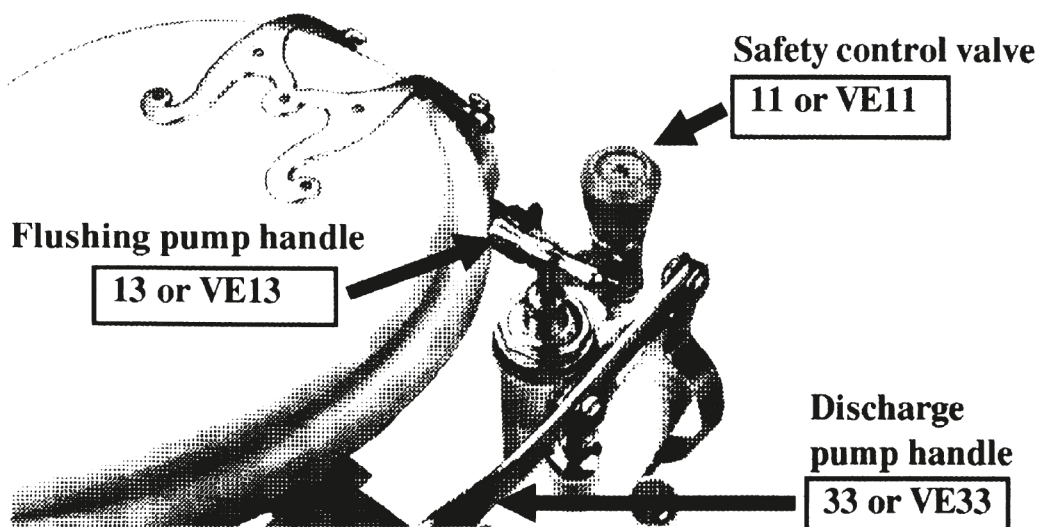

7. MAINTAINING YOUR MARINE TOILET

7.1. GENERAL

TOILET CLEANERS

The best cleaner for a marine toilet is frequent flushing, provided that the seawater is reasonably clean. Avoid using domestic cleaners that may contain bleach. Flushing through with soapy fresh water from time to time is a good idea as this will not only help in delaying scale deposit but will also help in keeping the bucket washers (**51** or **VE51**) supple. If deposits do build up these can be dissolved with vinegar which is best left in the system for 24 hours. Scale in pipes can largely be removed by taking the pipe off and bending it to crack off the deposits.

DAY TO DAY POINTS TO REMEMBER

- Do not use oil or grease in the toilet. Only use grease in the grease cups of the self adjusting gland type (made 1962-1974 - see pages 7,10,15 & 18) - we strongly recommend that Blakes seacock grease is used as this conforms to the correct specifications for a water-proof grease. Ensure that the operating instruction card is mounted where your guests will see it.
- Always flush the toilet thoroughly to ensure no waste is left in the discharge pipe.
- Occasionally flush through with soapy water.
- Put a notice on the toilet if you turn off the seacocks. You may burst a pipe or damage the toilet otherwise.
- Close the seacocks when you leave the boat.

SERVICING THE TOILET

Every 1-2 years, depending on use, it is a good idea to take your toilet on shore or on deck, strip it down, clean every part and replace all the perishable parts before reassembling it. A decent sized shifting spanner will undo most of the nuts and bolts. To purchase a full set of spanners and keys that fit every part

quote for **Baby & Minor** models: *EST3111; and for **Victory** model: *EST3222). Note: Spanners are referred to in this text with letters e.g. A (to purchase please quote EST.... number e.g. EST3110)

Included in Victory spanner kit: Spanner for 1½" Cap & lining outlet (V45)

EST3115

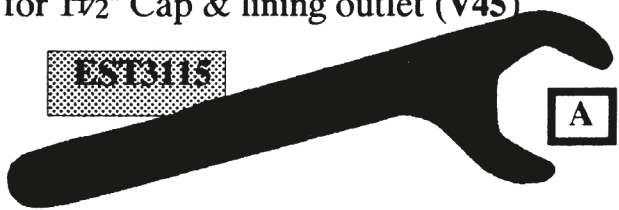

A

OPTIONAL SPANNER: for Victory 2" Cap & lining outlet (V45A)

EST3150

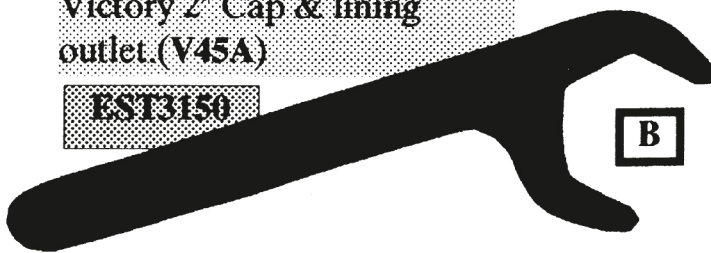

B

SPANNERS INCLUDED IN BOTH SPANNER KITS (*EST3111 or *EST3222)

EST3110



C

Spanner for **nut** of safety control valve spigot (12 or VE12)

EST3145



D

Spanner for back nut (10 or VE10)

EST3120

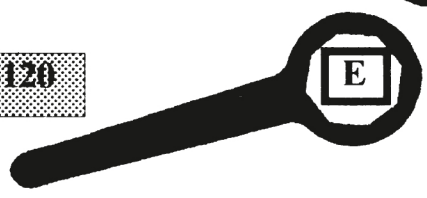

E

Spanner for Flushing pump top (81LS or VE81LS)

EST3125



F

Spanner for Lower valve housing (28 or VE28)

EST3130



G

Spanner for Hexagon cap nut (5 or VE5)

EST3135

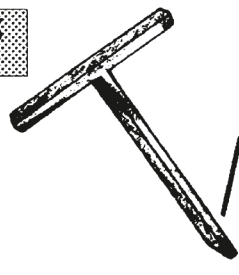

Key for spigot of Safety control valve (12 or VE12)

H

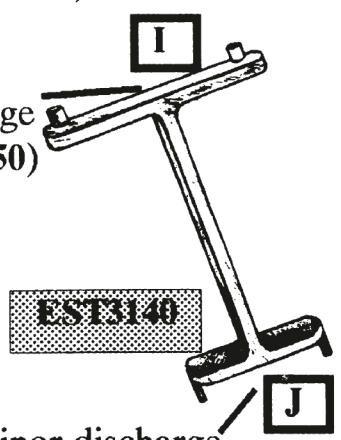

I

EST3140

J

Key for Baby/Minor discharge pump locking ring (50)

7.2. REMOVING THE TOILET UNIT

Page 4

Flush out and clean the toilet. Close the inlet and outlet seacocks. Loosen the jubilee clips to remove the hose connections on the inlet and outlet pumps (or in the case of cap & lining option (45 or V45) undo the cap (hexagon nut)) .

Page 12

Remove the 4 securing bolts on the base of the syphon pipe (1A or 1MA or VIA). Remove the toilet from the toilet space and take it ashore or on deck.

Page 5

Removal of seat and cover. Remove the nuts and washers from the left and right hand seat pillars (60 or V60). Lift the seat (64A or V64A) and cover (73A or V73A) clear and stow it in a safe position for cleaning.

Page 13

7.3. SERVICING THE DISCHARGE PUMP

GENERAL

On re-assembly always replace the rubber, leather and copper/asbestos parts - all these components are provided with the Cruising spares kits (see section 4, TABLE B). Note: only use jointing (sealing) compounds where specified.

Also take care to inspect the condition of the moving parts for undue wear (discharge spindle and gland nuts) as this may cause leakage even if the pump top seal is serviced.

7.3.1 BABY & MINOR MODELS

REMOVAL OF DISCHARGE UNIT FROM PUMP BODY

Page 8

Remove both sets of star lock capped washers (27A) with a screw driver.

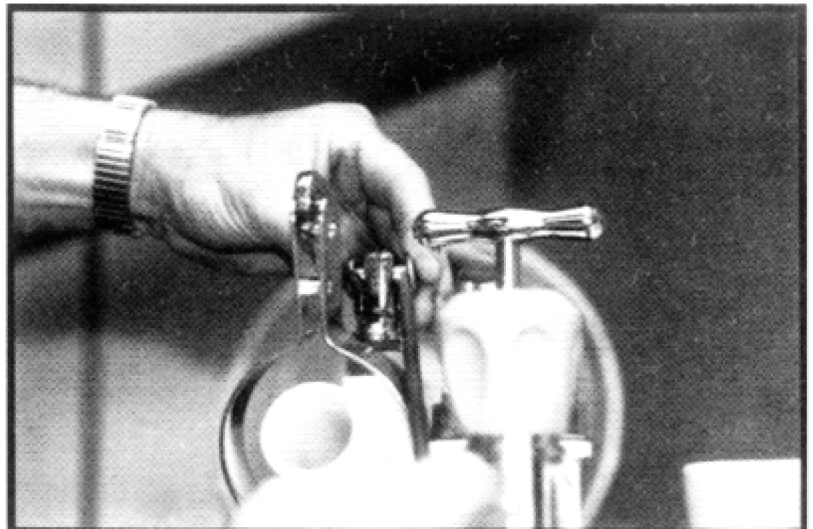

Remove the crosspins (35 & 36). The handle (33) can then be removed.

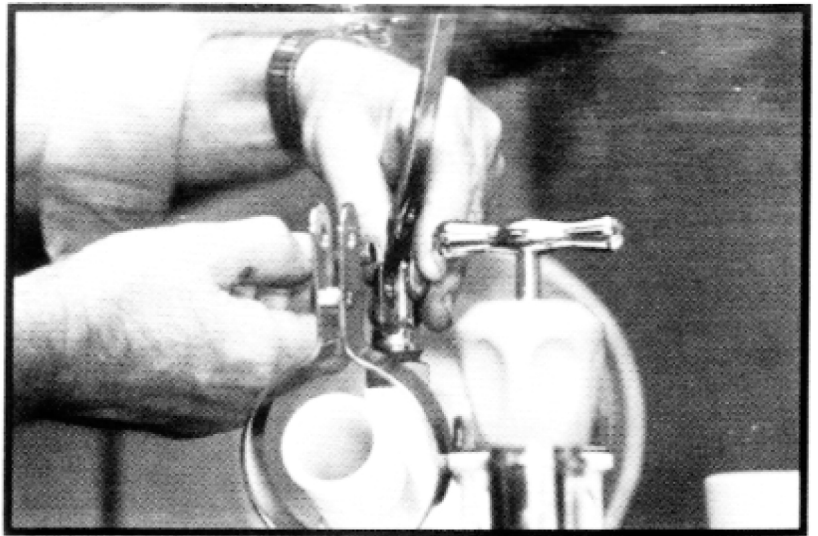

Remove the stirrup (34) from the outlet (76ALS) by undoing the nut and bolt (70).

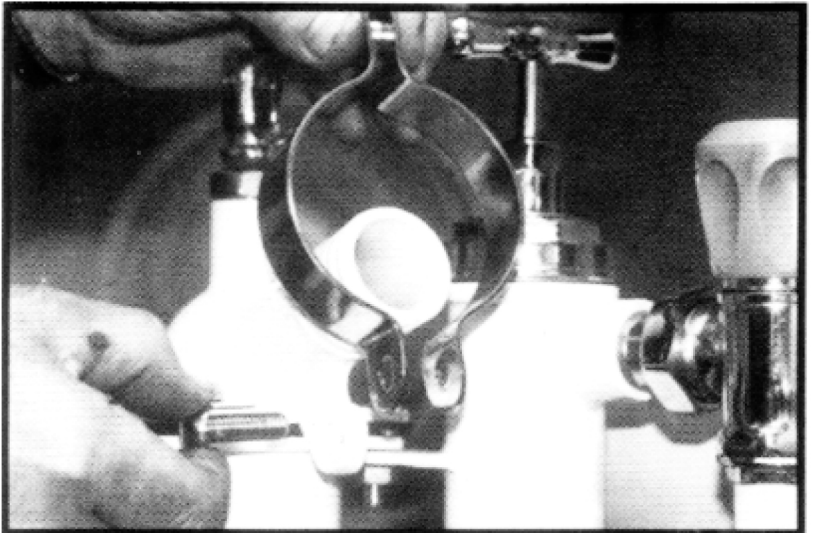

Page 7

Remove the 4 bolts (71, 3 x 70) from the top of the cylinder (76ALS) and lift the discharge unit completely free from the cylinder.

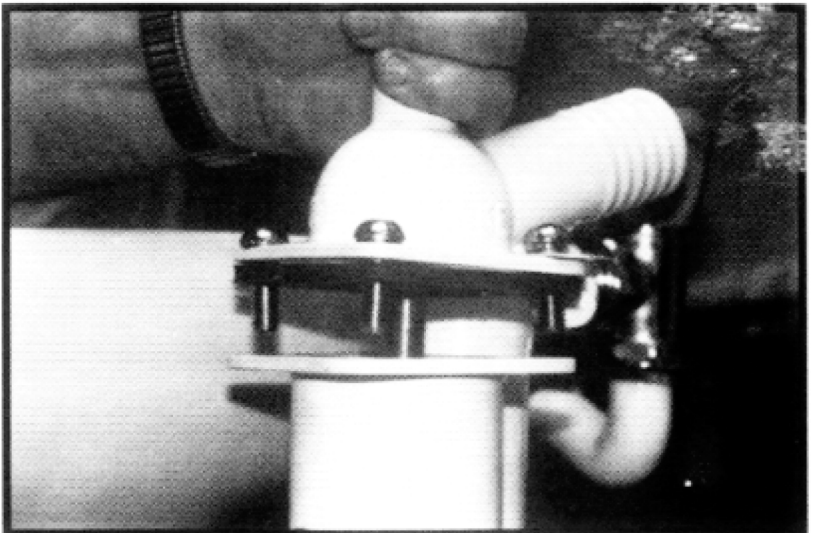

SERVICING DISCHARGE UNIT - EXAMINATION AND REPLACEMENT OF WEIGHTED BALL (52), RUBBER BUCKET WASHERS (51) AND LEATHER WASHER (38)

Remove the centre weighted ball (52) which should be renewed if it is worn.

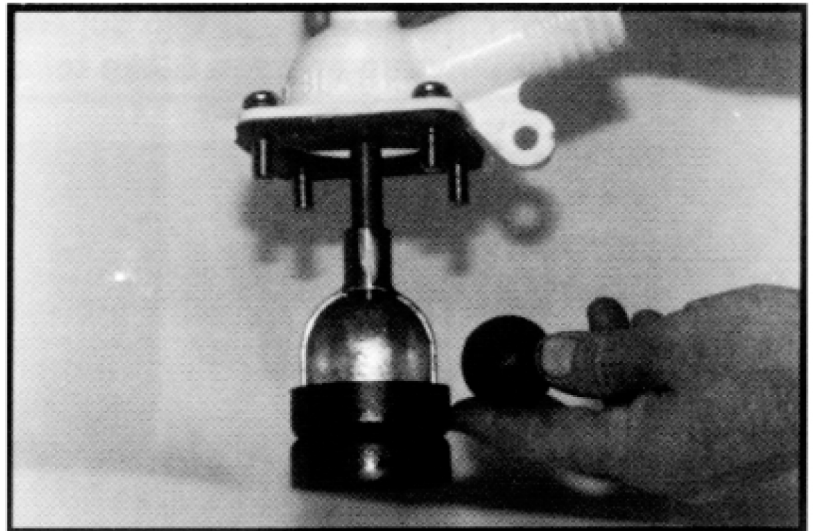

Anchor the pump top by slipping the double lug (37) over a thin bar or spanner handle that is held in a bench vice. This will allow the unscrewing of the piston locking ring (50) from the hooded piston (48) - use key J

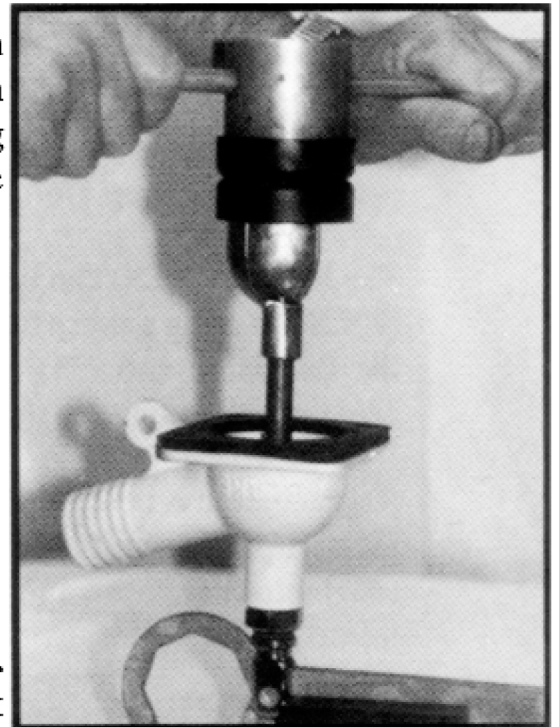
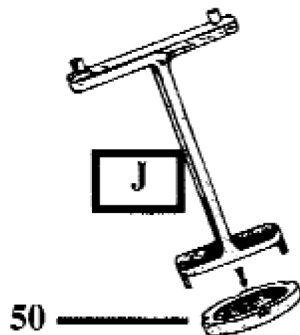

Remove the rubber bucket washers (51). Replace. Note: the tolerance on bucket washers is oversize to allow for any wear on the cylinder, therefore it may be necessary to take a little of the material off the outer circumference - as evenly as possible - using a file or emery paper

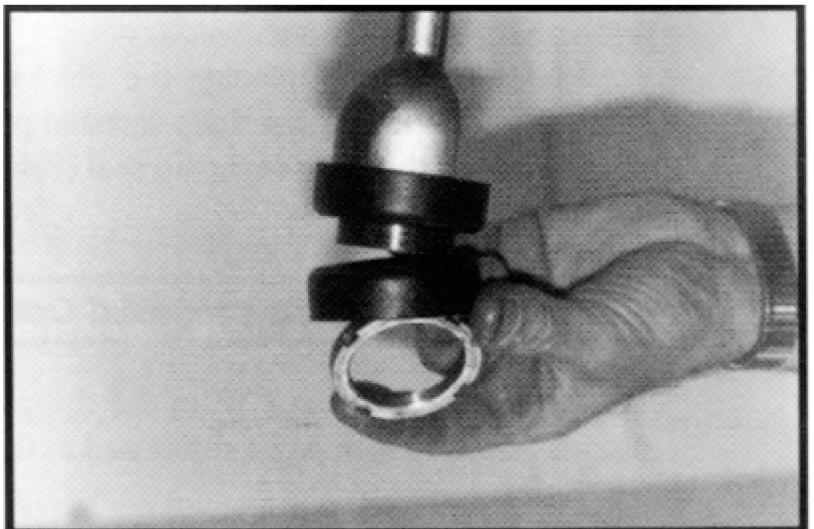

SERVICING DISCHARGE UNIT - PUMP TOP SEAL.

Lip seal type: - note that this superior seal modification can be used to upgrade any age Blake toilet.

To access the lip seal (78LS) in the the pump top (76ALS) or gland nut (77LS) the pump top and discharge rod (39) must be separated. Hold the discharge rod (39) in a soft jaw vice to unscrew the double lug (37). Remove the leather washer (38). The discharge rod (39) can now be carefully with-
drawn from the top (76ALS or 76A).

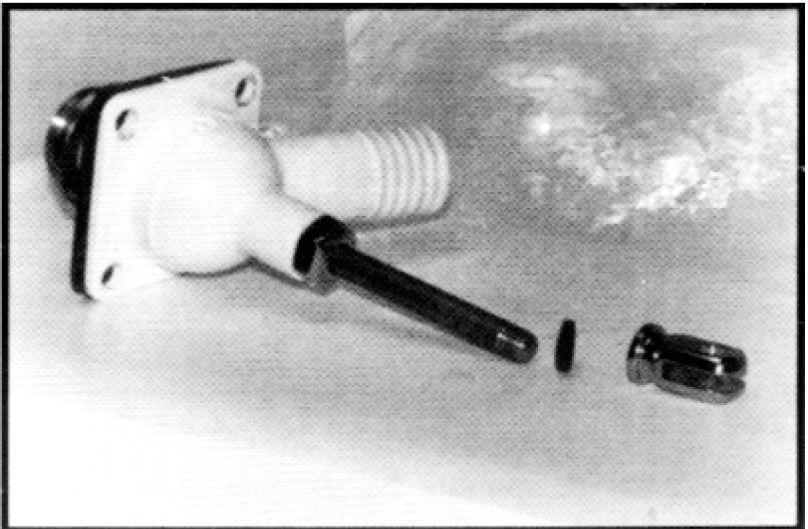

The lip seal (78LS) can be removed from the pump top (76ALS) or gland nut (77LS) by using a sharp tool or piece of wire. It should be noted that whenever the discharge rod (39) is removed it is imperative the lip seal (78LS) is replaced as damage to the lip seal is a definite possibility.

Replacement is best done by inserting the lip seal (with the flat top of the seal facing upwards and the cup shape facing down towards the hooded piston (48)) into the groove and using the flat end of a lead pencil or bic pen to ease it into place.

ASSEMBLE IN REVERSE ORDER

WARNING: When replacing the discharge rod (39) the initial threaded section should be very **carefully screwed** past the lip seal (78LS). If this is not done carefully the edge of the lip seal (78LS) will be damaged and may cause future leaking.

O-Ring type - models produced Oct 1974 - End 1991

To replace the O-Ring (78) in the the pump top (76A) the pump top and discharge rod (39) must be separated as described for the lip seal type above.

To remove the O-Ring (78) first remove the gland nut (77) from the pump top (76A). Replace the O-Ring (78) with a new one

ASSEMBLE IN REVERSE ORDER

WARNING: When replacing the discharge rod (39) the initial threaded section should be very **carefully screwed** past the O-Ring seal (78). If this is not done carefully the inside edge of the O-Ring seal will be damaged and may cause future leaking.

Gland packing type - models produced prior Oct 1974

In these models the seal is made by winding graphite gland packing (72 or VE72 -supplied as standard in the Cruising spares kits - see section 4, TABLE B) around the shaft of discharge rod (39) just under the self adjusting gland nut (17 or VE17) or old type gland nut (15 or VE15). There is no need to remove the discharge rod from the pump top to service the

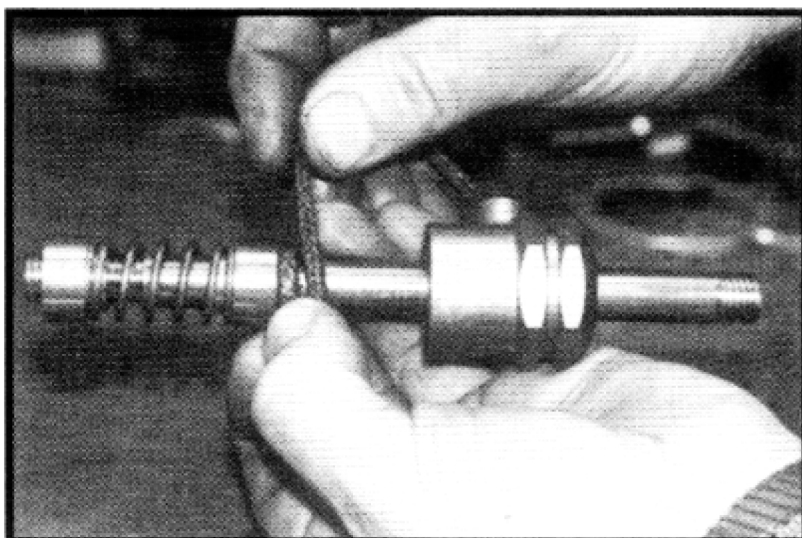

seal. Detailed instructions for these two types now follow:

For models between 1962 - Oct 1974 using the self adjusting gland nut. Unscrew the self adjusting gland nut (65). Remove the old grease and gland packing. Put on some new grease - Blakes Seacock is recommended as this has the correct specifications - and wind one turn of gland packing at the top of the spring and three turns below the spring (43) using the gland collars (44) as shoulders. Note: this is a guide only, the objective should be to use enough gland packing so that the gland nut (65) takes up at least two threads on the pump top. After a bit of use it will be necessary to retighten but plenty of thread will be left for future adjustment.

With pre-1962 models using the old type gland nut (41). Unscrew the gland nut (41) from the pump top (40). Remove the old gland packing and neatly wind about 6-8 turns of new graphite gland packing onto the shaft of the discharge rod (39) and pack into the pump top (40). Screw down the gland

nut (41) while simultaneously working the discharge rod (39) to bed down the packing. Again the objective should be to wind enough gland packing to allow the gland nut to take up at least two full turns (threads) in the pump top (40). This will leave plenty of room for future adjustment.

SERVICING THE LOWER VALVE OF DISCHARGE PUMP

Unscrew the 4 assembly bolts at the base of the discharge cylinder (2). Lift the cylinder (2) clear of the syphon pipe (1A or 1MA).

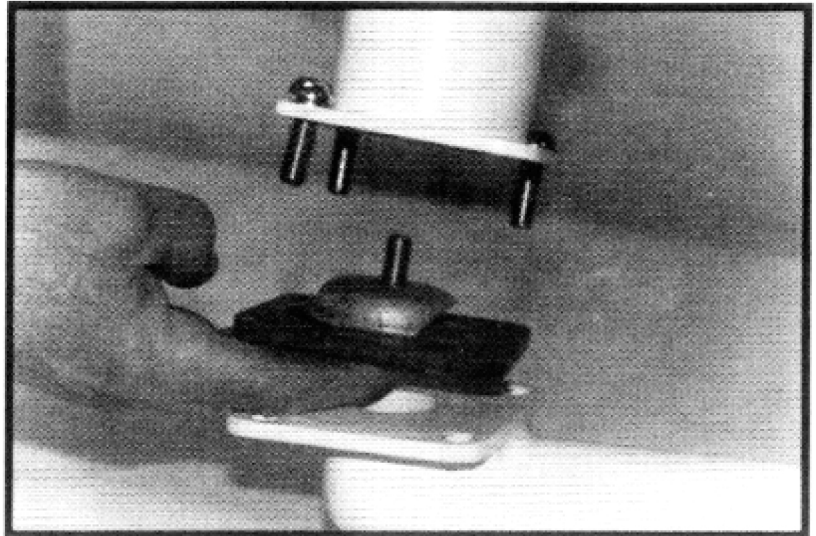

The lower cylinder joint is a combined valve and joint (seal). The old type (54) design relied on a brass ball (53) for gravity closure. Current models use a superior clack type valve with a "pressure" lip for excellent sealing (84). This can be fitted to all ages of toilets and is supplied as a matter of course in the Cruising spares kit *TBB0782 (see section 4, TABLE B).

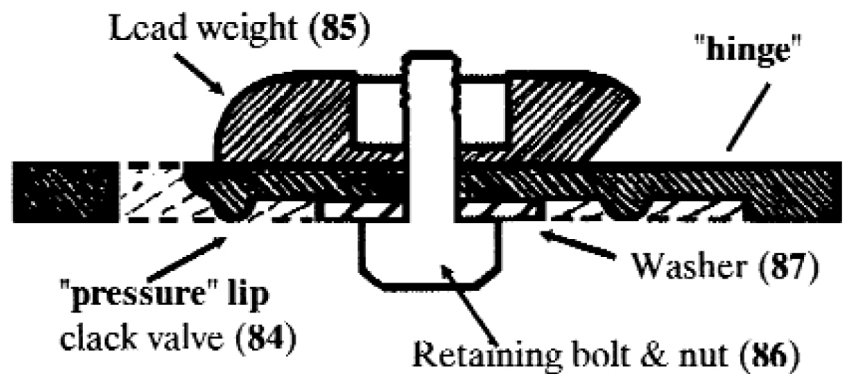

Remove the clack valve assembly from the syhon pipe (1A or 1MA). Clean the syphon pipe thoroughly, checking that there are no obstructions. On replacement ensure the "hinge" of the clack valve is nearest the toilet pan (59A or V59A) so it opens in the correct way.

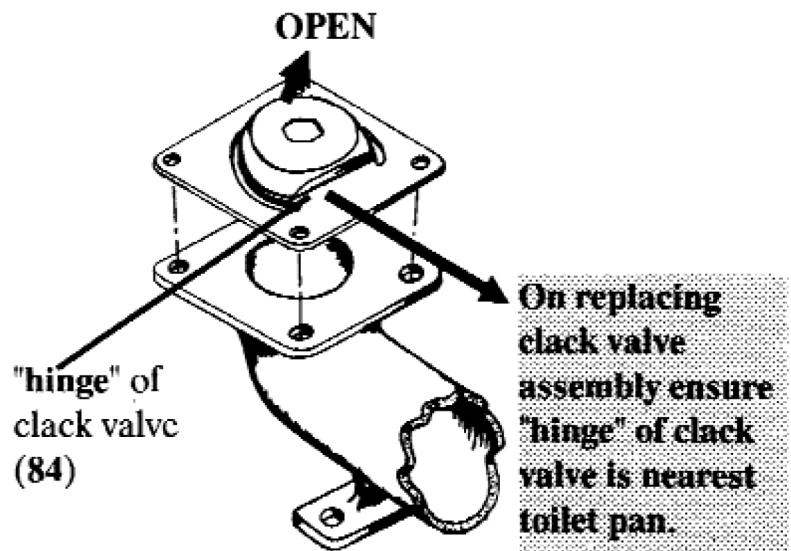

7.3.2 VICTORY MODEL

REMOVAL OF DISCHARGE UNIT FROM PUMP BODY

Page 16 To remove the crosspins (2 x VE36, VE35) first remove the star lock capped washers (27A) with a screw driver. The handle (VE33) can then be removed.

Page 15 Remove the 6 bolts (VE70) from the discharge pump top (VE84LS).

Page 14 Withdraw the discharge unit from the cylinder (VE2).

SERVICING DISCHARGE UNIT - EXAMINATION AND REPLACEMENT OF WEIGHTED BALL (VE52), RUBBER BUCKET WASHERS (VE51) AND LEATHER WASHER (VE38)

Remove the centre weighted ball (VE52) which should be renewed if it is worn.

Anchor the pump top by slipping the double lug (VE37) over a thin bar (6mm) or spanner handle that is held in a bench vice. This will allow the unscrewing of the piston locking ring (VE50) from the hooded piston (VE48) - use key I.

The bucket washers (VE51) can then be removed along with the combing ring (VE76). Note: the tolerance on bucket washers is oversize to allow for any wear on the cylinder, therefore it may be necessary to take a little of the material off the outer circumference - as evenly as possible - using a file or emery paper

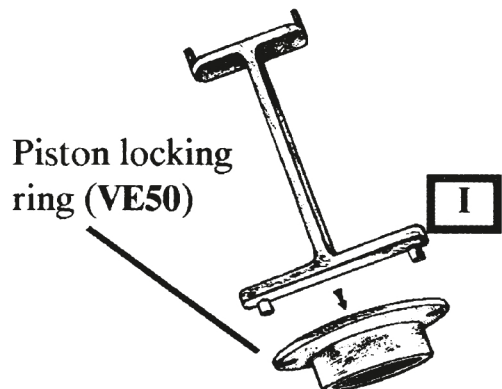

Page 15 SERVICING DISCHARGE UNIT - PUMP TOP SEAL.

Lip seal type: - note that this superior seal modification can be used to upgrade any age Blake toilet.

To access the lip seal (VE86LS) in the the pump top (VE84LS) or gland nut (VE85LS) the pump top (VE84LS or VE84) and discharge rod (VE37A) must be separated. Hold the discharge rod (VE37A) in a soft jaw vice to unscrew the double lug (VE37). Remove the leather washer (VE38). The discharge rod (VE37A) can now be carefully withdrawn from the top (VE84LS or VE84).

The lip seal (VE86LS) can be removed from the pump top (VE84LS) or gland nut (VE85LS) by using a sharp tool or piece of wire. It should be noted that

whenever the discharge rod (VE37A) is removed it is imperative the lip seal (VE86LS) is replaced as damage to the lip seal is inevitable.

Replacement is best done through inserting the lip seal (with the flat top of the seal facing upwards and the cup shape facing down towards the hooded piston (VE48)) into the groove and using the flat end of a lead pencil or bic pen to ease it into place.

ASSEMBLE IN REVERSE ORDER

WARNING: When replacing the discharge rod (VE37A) the initial threaded section should be very **carefully screwed** past the lip seal. If this is not done carefully the edge of the lip seal (VE86LS) will be damaged and may cause future leaking.

O-Ring type - models produced Oct 1974 - End 1991

To access the O-Ring (VE86) in the the pump top (VE84) the pump top and discharge rod (VE37A) must be separated as described for the lip seal type above. To remove the O-Ring (VE86) first remove the gland nut (VE85) from the pump top (VE84).

Replace the O-Ring (VE86) with a new one

ASSEMBLE IN REVERSE ORDER

WARNING: When replacing the discharge rod (VE37A) the initial threaded section should be very **carefully screwed** past the O-Ring seal (VE86) If this is not done carefully the inside edge of the O-Ring seal will be damaged and may cause future leaking.

Gland packing type - models produced prior Oct 1974

In these models the seal is made by winding graphite gland packing (VE72) (supplied as standard in the Cruising spares kits (see section 4, TABLE B) around the shaft of the discharge rod (VE37A) just under the self adjusting gland nut (VE65) or old type gland nut (VE41). There is no need to remove the discharge rod from the pump top to overhaul the seal. Detailed instructions for these two types now follow:

For models between 1962 - Oct 1974 using the self adjusting gland nut. Unscrew the self adjusting gland nut (VE65). Remove the old grease and gland

packing. Put on some new grease - Blakes Seacock is recommended as this has the correct specification - and wind one turn of gland packing at the top of the spring (VE43) and three turns below the spring (VE43) using the gland collars (VE44) as shoulders. Note: this is a guide only, the objective should be to use enough gland packing so that the gland nut (VE65) takes up at least two threads on the pump top (VE42). After a bit of use it will be necessary to retighten but plenty of thread will be left for future adjustment.

With pre-1962 models using the old type gland nut (VE41). Unscrew the gland nut (VE41) from the pump top (VE40). Remove the old gland packing and neatly wind about 6-8 turns of new graphite gland packing onto the shaft of the discharge rod and pack into the pump top (VE40). Screw down the gland nut (VE41) while simultaneously working the discharge rod (VE37A) to bed down the packing. Again the objective should be to wind enough gland packing to allow the gland nut to take up at least two full turns (threads) in the pump top (VE40). This will leave plenty of room for future adjustment.

ASSEMBLE IN REVERSE ORDER

Page 14 SERVICING THE TOP VALVE ASSEMBLY OF DISCHARGE PUMP

Remove the 4 bolts from the outlet (V39).

Lift off the outlet (V39) and top valve assembly (VE54 and VE53). Clean and replace perishable parts.

Page 12

ASSEMBLE IN REVERSE ORDER

SERVICING THE LOWER VALVE OF DISCHARGE PUMP

Unscrew the 6 bolts (VE71) bolts at the base of the discharge cylinder (VE2). Lift the cylinder (VE2) clear of the syphon pipe (V1A).

The lower cylinder joint VE47 can now be removed for examination and replacement.

The rubber facing (VE79) on the lower clack valve (VE77) can be removed by unscrewing the retaining screw (VE80).

Remove the clack valve (VE77) by withdrawing pin (VE78).. Clean the syphon pipe thoroughly, checking that there are no obstructions.

ASSEMBLE IN REVERSE ORDER

7.4. SERVICING THE FLUSHING PUMP

7.4.1 GENERAL

On re-assembly always replace the rubber, leather and copper/asbestos parts - all these components are provided in the Cruising spares kits (see section 4, TABLE B). Only apply semi-hardening jointing compound (eg Hermetite) where specified.

Also take care to inspect the condition of the moving parts for undue wear (T-handle shaft (or pump spindle) and gland nuts) as this may cause leakage even if the pump top seal is overhauled.

7.4.2 ALL MODELS

REMOVAL OF PUMP BODY

Page 9

Page 17

Use **Spanner C** to disconnect the wheel control valve (11 or VE11) by unscrewing the nut (12 or VE12).

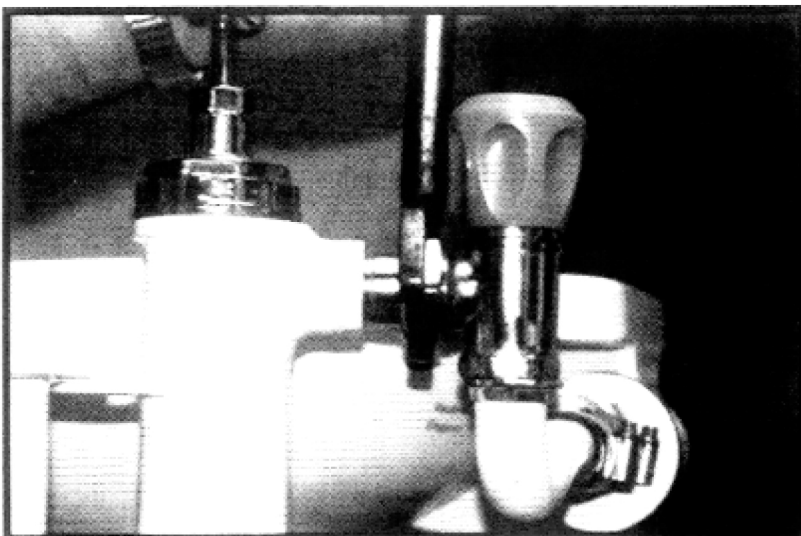

Remove the assembly bolt (2 bolts in the case of the Minor model) at the base of the flushing pump unit. The flushing pump unit is now free for further dismantling.

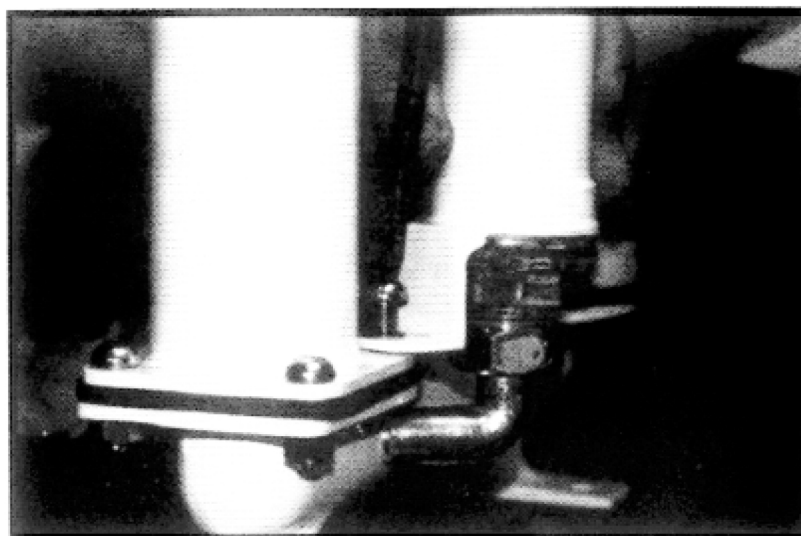

SECURING PUMP BODY IN FURTHER OPERATIONS

For further operations the flushing pump body must be prevented from turning. To prevent damaging the pump body use **key H**. This is held in a vice and locates in the wheel control valve spigot (**12** or **VE12**) between two lugs and prevents the pump body from turning.

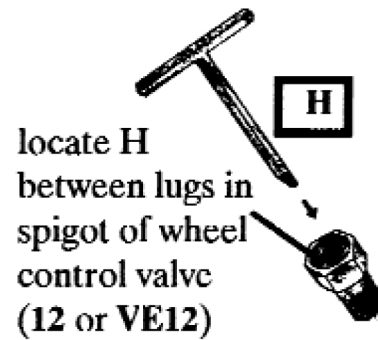

REMOVAL OF FLUSHING UNIT FROM PUMP BODY

The flushing pump top has a shallow octagonal top and it is recommended that **spanner E** is used to unscrew the top.

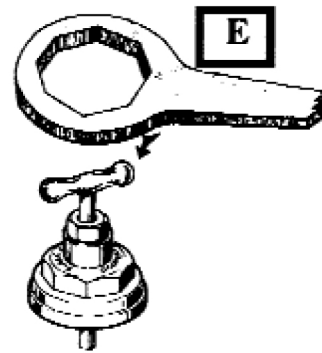

Withdraw the pump assembly.

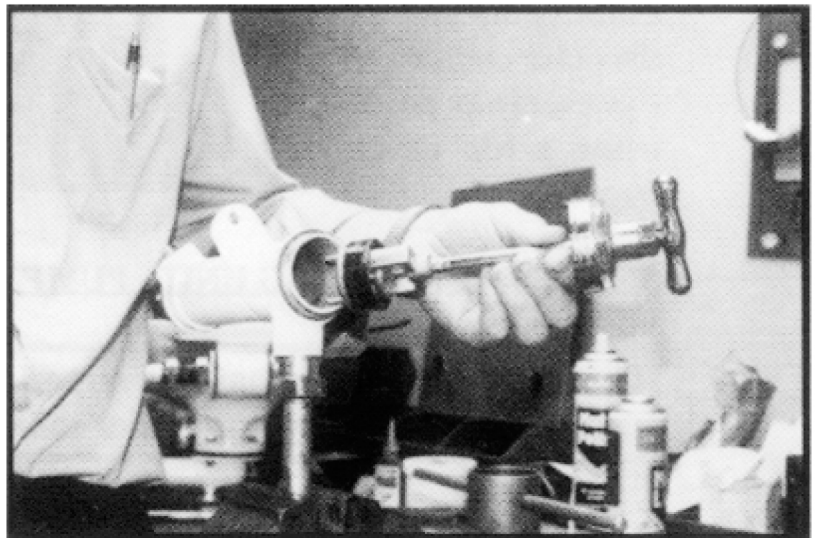

SERVICING FLUSHING UNIT - EXAMINATION AND REPLACING RUBBER BUCKET WASHER (25 OR VE25)

Hold the valve plug (24 or VE24) in a vice. Locate a screwdriver (or bar) through the bridge piece (23 or VE23) and unscrew from the valve plug (24 or VE24).



This will allow removal of the bucket washer (25 or VE25). Replace. Note: the tolerance on bucket washers is oversize to allow for any wear on the cylinder, therefore it may be necessary to take a little of the material off the outer circumference - as evenly as possible - using a file or emery paper

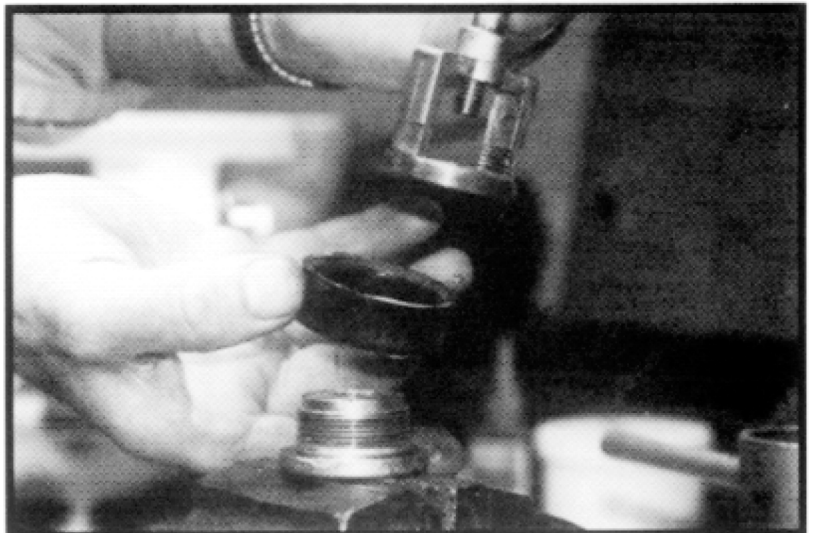

Page 10

SERVICING FLUSHING UNIT - PUMP TOP SEAL.

Page 18

Lip seal type: - note that this superior seal modification can be used to upgrade any age Blake toilet.

To access the lip seal (83LS or VE83LS) in the the pump top (81LS or VE81LS) or gland nut (82LS or VE82LS) the pump top and T-handle (13 or VE13) must be separated. Remove the bridge piece (23 or VE23) by holding the T-handle (13 or VE13) in a soft jaw vice and then unscrewing the bridge piece (23 or VE23) by inserting a screwdriver or bar through its legs. The pump top is now free to be pulled off the T- handle(13 or VE13).

The lip seal (83LS or VE83LS) can be removed from the pump top (81LS or VE81LS) or gland nut (82LS or VE82LS) by using a sharp tool or piece of wire. It should be noted that whenever the T-handle is removed it is imperative the seal is replaced as damage to the seal is inevitable.

Replacement is best done through inserting the lip seal (with the flat top of the seal facing upwards and the cup shape facing down towards the bridge piece (23 or VE23)) in the groove and using the flat end of a lead pencil or bic pen to ease it into place.

ASSEMBLE IN REVERSE ORDER.NOTE: APPLY SEMI-HARDENING JOINTING COMPOUND TO THE THREADS ON THE PUMP TOP.

WARNING: When replacing the T-handle (13 or VE13) the initial threaded section should be very **carefully screwed** past the lip seal (83LS or VE83LS). If this is not done carefully the edge of the lip seal will be damaged and cause future leaking.

O-Ring type - models produced Oct 1974 - End 1991

To access the O-Ring (83 or VE83) in the the pump top (81 or VE81) the pump top and T-handle (13 or VE13) must be separated. Remove the bridge piece (23 or VE23) as described for the lip seal type above. The pump top can then be pulled off the T-handle along with washer (22 or VE22).

Remove the gland nut (82 or VE82) and O-ring seal (83 or VE83) from the pump top. Replace the O-Ring with a new one

ASSEMBLE IN REVERSE ORDER.NOTE: APPLY SEMI-HARDENING JOINTING COMPOUND TO THE THREADS ON THE PUMP TOP.

WARNING: When replacing the T-handle (13 or VE13) the initial threaded section should be very **carefully screwed** past the O-Ring seal (83 or VE83). If this is not done carefully the inside edge of the O-Ring seal will be damaged and cause future leaking.

Gland packing type - models produced prior Oct 1974

In these models the seal is made by winding graphite gland packing (72 or VE72) - supplied as standard in the Cruising spares kits (see section 4, TABLE B) - around the shaft of the T-handle (13 or VE13) just under the self adjusting

gland nut (17 or VE17) or old type gland nut (15 or VE15). Detailed instructions follow:

For models between 1962 - Oct 1974 using the self adjusting gland nut. Unscrew the self adjusting gland nut (17 or VE17). Remove the old grease and gland packing. Put on some new grease - Blakes Seacock is recommended as this has the correct specifications - and wind one turn of gland packing at the top of the spring and three turns below the spring (18 or VE18) using the gland collars (19 or VE19) as shoulders. Note: this is a guide only, the objective should be to use enough gland packing so that the gland nut (17 or VE17) takes up at least two threads on the pump top (16 or VE16). After a bit of use it will be necessary to retighten but plenty of thread will be left for future adjustment.

With pre-1962 models using the old type gland (15 or VE15). Unscrew the gland nut (15 or VE15) from the pump top (14 or VE14). Remove the old gland packing and neatly wind about 6-8 turns of new graphite gland packing onto the shaft of the T-handle and pack into the pump top (14 or VE14). Screw down the gland nut while simultaneously working the T-handle to bed down the packing. Again the objective should be to wind enough gland packing to allow the gland nut to take up at least two full turns (threads) in the pump top (14 or VE14). This will leave plenty of room for future adjustment.

ASSEMBLE IN REVERSE ORDER. NOTE: APPLY SEMI-HARDENING JOINTING COMPOUND TO THE THREADS ON THE PUMP TOP.

Page 9

OVERHAULING FLUSHING UNIT - LOWER VALVE ASSEMBLY

Page 17

This should only be done in major services or if the flushing pump is not drawing well as it indicates excess wear and thus poor seating between the lower valve (29A or VE29A) and lower valve housing (28 or VE28).

Ensure the pump body is held secure as described on page 42.

Remove the heavy valve assembly at the bottom end using spanner F.



Hold the lower valve housing (28 or VE28) in a bench vice. Remove the lower valve nut to dismantle the assembly.



Inspection of surfaces will indicate if there is excess wear, if so replace the necessary components.



ASSEMBLE IN REVERSE ORDER. NOTE: APPLY SEMI-HARDENING JOINTING COMPOUND TO THE THREADS ON THE LOWER VALVE HOUSING.

7.5. REMOVAL AND REPLACEMENT OF THE WHEEL CONTROL VALVE ASSEMBLY

7.5.1 ALL MODELS

If there is a continual trickle of flushing water into the pan, when the safety control valve (11 or VE11) is fully closed, this indicates that the seating on the wheel control valve (11 or VE11) is worn, the solution is replacement of the complete unit.

Undo nut (12 or VE12). The spigot of 12 or VE12 will remain in the pump body. If you wish to replace this - as new wheel control valves are supplied with 12 or VE12 - then you need to use key H to remove it



H

Remove the control valve (11 or VE11) from the back pipe (9 or 4M or VE9) by holding the back pipe in a soft jawed vice, simultaneously holding the control valve body with a screwdriver and undoing nut (10 or VE10) with spanner D.

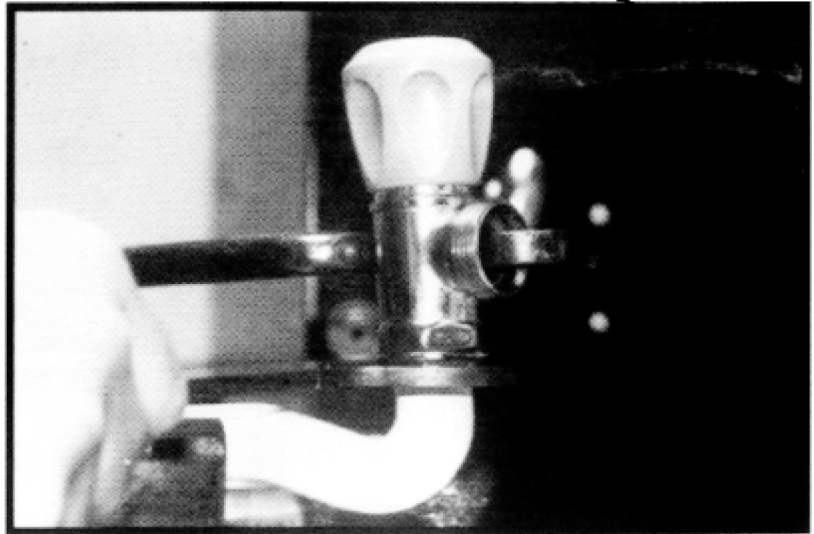

ASSEMBLE IN REVERSE ORDER. NOTE: APPLY SEMI-HARDENING JOINTING COMPOUND TO THE THREADS ON THE NUT (10 or VE10).

7.6. SERVICING TOILET PAN

Page 5

7.6.1 BABY & VICTORY MODELS

Page 13

Remove the hose connection (7 or V7) from the back pipe (9 or VE9) by slackening the jubilee clip (8 or VE8) and easing the hose connection off

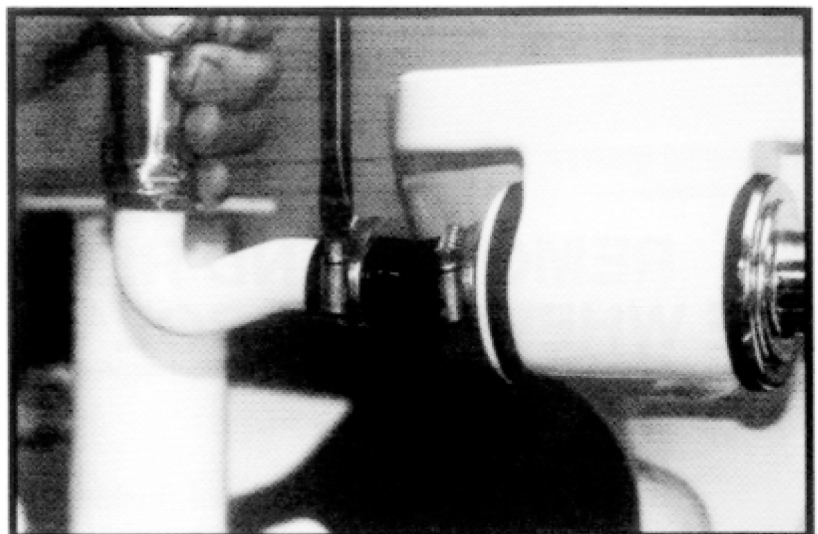

Undo the cap nut (5 or VE5) using spanner G. Remove the cap nut and washer (6 or VE6). Pull out the back connection (4 or VE4) complete with washer (6 or VE6).

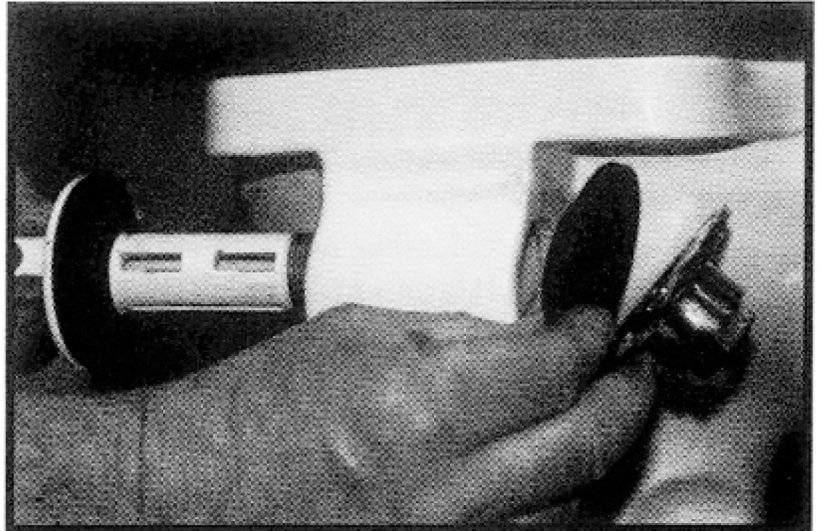

Page 4 The toilet pan (59A) can be removed by unscrewing the four retaining bolts (56A). Replace if necessary the pan joint (55 or V55) and retaining bolt washers (all supplied with the Cruising spares kit - see section 4, TABLE B).

Page 12

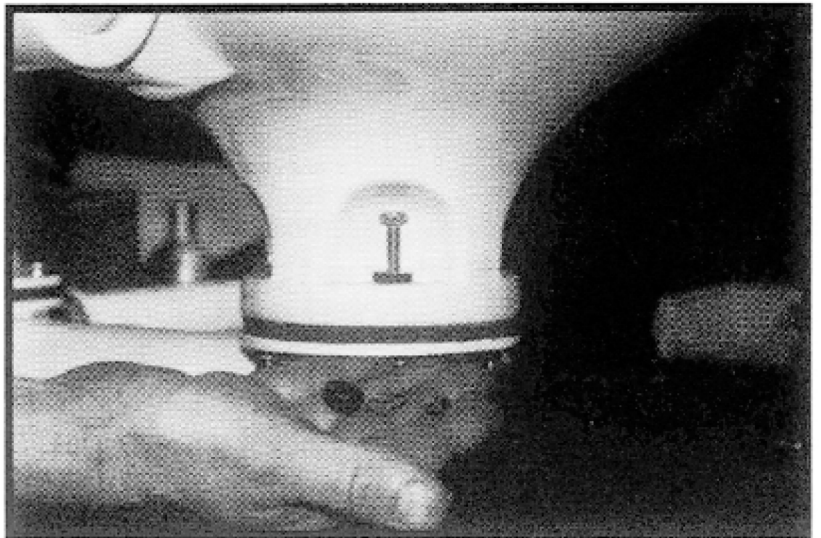

ASSEMBLE IN REVERSE ORDER. NOTE: APPLY SILICON SEALANT TO THE PAN JOINT (55 or v55).

7.6.2 MINOR MODEL

Page 5 Remove the hose connection (7M) from the pump body (3M) by slackening the jubilee clip (8) and casing the hose connection off.

Undo the cap nut (5) using the spanner provided with the spanner kit. Remove this and the washer (6). Pull out the back connection (4M) complete with washer (6) and wheel control valve (11).

Page 4 The toilet pan (59A) can be removed by unscrewing the four retaining bolts (56A). Replace if necessary the pan joint (55) and retaining bolt washers (all supplied with the standard Cruising spares kit). The toilet pan (59A) can be removed by unscrewing the four retaining bolts (56A).

ASSEMBLE IN REVERSE ORDER. NOTE: APPLY SILICON SEALANT TO THE PAN JOINT (55).

7.7. NOTES ON CLEANING AND REFITTING THE PARTS

All rubber, leather and copper asbestos parts should be replaced at every overhaul. It is important to note that the two copper and asbestos washers (22 or VE22) have different internal diameters - the thicker washer fitting on the bottom of the flushing pump. Only use jointing (sealing) compound where specified in the instructions.

When the toilet is completely dismantled the pan may be cleaned with scouring agents.

Penetrating oil, paraffin or petrol can be used to clean the dismantled metal parts, but only after all the rubber components have been taken off.

The discharge pipe must be kept clear of obstructions and this should be inspected at laying up time. The bore diminishes about 1/8" in diameter each year and normally at the end of 10 years in use the pipe should be thoroughly cleaned out or replaced.

The safety control valve (11 or VE11) - prevents flooding from the flushing water intake - is particularly important in a deep draught sailing yacht. This valve is not an item that can be serviced and if it becomes faulty i.e. if it leaks or does not shut the water off properly, it will have to be replaced.

7.8. OVERHAULING OLDER MODELS

This is well described in the relevant sections on overhauling the pumps. It is important nevertheless to stress that the parts normally worn on older units are the flush pump spindle, the gland nut, the discharge spindle and the gland nut. These items should be replaced if well worn - see **section 4**.

7.9. PROCEDURE TO AVOID FROST DAMAGE IN WINTER

Close both seacocks and hang a notice on the toilet to ensure that people do not use it. Disconnect the inlet pipe from the flushing pump and the seacocks and drain the pipe.

Empty water from the flushing pump by moving the inlet pipe away from the bottom of the pump, raising the spindle and tripping the lower valve with the finger. Hold until the pump is empty.

Disconnect the discharge pipe at the seacocks, place the end into a bucket and pump the discharge water into the bucket.

Ideally, the discharge and inlet pipes should be disconnected from the toilet and the complete toilet removed from the boat by undoing the bolts at its base. Take the toilet ashore and drain the flushing pump as above and the discharge pump by tilting the unit and allowing the water to flow out of the outlet. Disconnect the inlet and discharge pipes from the seacocks and drain them.

If you would like any further advice or help on dismantling and overhauling your toilet, please contact us either by phone or by letter at the address on the back of this handbook.

8. CHECK POINTS

| PROBLEM | POSSIBLE CAUSE | SOLUTION |
|---------------------------------|--|--|
| Discharge pump becomes stiff to | Scale deposit build up in pump cylinder (2 or VE2) | With time, depending on salinity and temperature of the sea water, scale deposit will build up in the discharge pump and hose. The warmer and more salty the water, the faster this deposit will form. It can be removed by stripping the pump (see section 7.3) and chipping it off or, by soaking it in vinegar to dissolve it. Scale is best removed from the discharge hose by physically bending and "working" the pipe so that the scale is dislodged and falls out. If it is possible to remove the hose, this task is made much easier. |
| | Oil or grease in the pump | NEVER use oil or grease to lubricate either of the pump cylinders. It will cause the bucket washers (51 or VE51) to expand and eventually seize in the cylinder, if this happens the bucket washers must be replaced. The best pump lubricant is liquid soap. When replacing the bucket washers note that they are supplied over size to take up any wear on old cylinders. This may mean the pump is stiff to operate having just replaced the bucket washers. To remedy this situation, remove excess material from the outer circumference – use a file or emery paper. |
| Flushing pump loses priming | Bucket washer worn | Replace bucket washer. It may be necessary to lightly abrade the new washer to get a good sliding fit as described above. Liquid soap will act as a suitable lubricant. |
| | Lower valve not seating correctly | The lower valve (29A or VE29A) – see pages 9 or 17 – is aluminium Bronze and has a ground seating. If the seating is damaged, worn or has debris interfering with it, it will be fairly clear on dismantling – see pages 45 and 46. Either clear the debris or re-grind the valve using grinding paste – replacement of the complete assembly may be necessary. |

| PROBLEM | POSSIBLE CAUSE | SOLUTION |
|---|---|--|
| Water runs back to bowl after discharge pumping | Safety Control Valve (11 or VE11) leaking | Ensure the Safety Control Valve is closed, then close the inlet seacock as well. If the water stops running back into the bowl (59A or V59A) the Safety control valve is faulty and should be replaced – see section 7.5.1. |
| | Discharge clack valve not holding. | If, having carried out the above test, the water still runs back into the bowl then it is the discharge pump which is at fault. Water will be leaking back into the bowl past the weighted clack valve. The weighted clack valve may be held open by debris or, it may be leaking because of general wear on the valve faces. Clean and replace if necessary. Note that since Mar 1991 all new toilets have an improved "pressure" lip valve (84) see page 37 – this improved valve is supplied as a matter of course in the (Baby or Minor) Cruising spares kit – see section 4, TABLE B. |
| Glands leak on inlet or discharge pumps | O rings worn – Gland packing worn – Pump spindles or Gland nuts worn | Depending on the age of the toilet, it will be fitted with lip seals, O ring glands or gland packing – see pages 7,10,15 & 18. Instructions for servicing these seals are given in sections 7.3 and 7.4. After some years the pump spindles and gland nuts may wear resulting in the gland leaking at mid stroke of the pump – even after replacing with new lip seals, O rings or gland packing. Check spindles and gland nuts for wear and replace as necessary. |

9. DIMENSIONS AND SPECIFICATIONS

THE BLAKES BABY

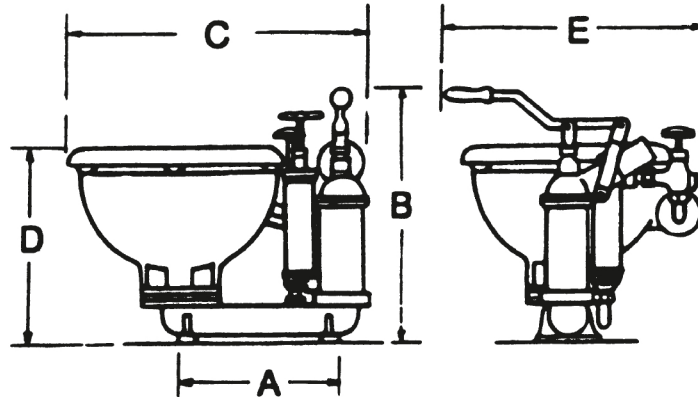

Dimensions

A - 10½" (270mm)

D - 14½" (368mm)

B - 17½" (440mm)

E - 19" (483mm)

C - 20" (510mm)

- ✱ **Weight** — approx 20 kg
- ✱ **Discharge Pump** — hose connection outlet for 1½" bore flexible hose (for metal plumbing cap and lining option is available)
- ✱ **Rigid Handle** — provided as standard for discharge pump (detachable handle option available)
- ✱ **Flushing Pump** — connections for ¾" bore flexible hose or metal plumbing

THE BLAKES MINOR

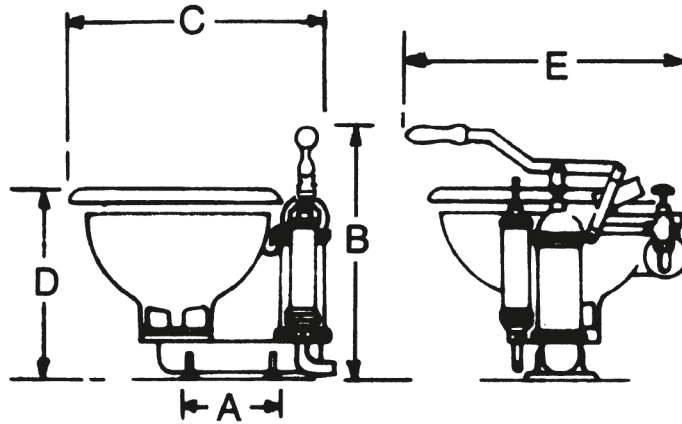

Dimensions

A - 7" (180mm)

D - 14½" (368mm)

B - 17½" (440mm)

E - 19" (483mm)

C - 18" (460mm)

- ✱ **Weight** — approx 20 kg
- ✱ **Discharge Pump** — hose connection outlet for 1½" bore flexible hose (for metal plumbing cap and lining option is available)
- ✱ **Rigid Handle** — provided as standard for discharge pump (detachable handle option available)
- ✱ **Flushing Pump** — connections for ¾" bore flexible hose or metal plumbing

THE BLAKES VICTORY

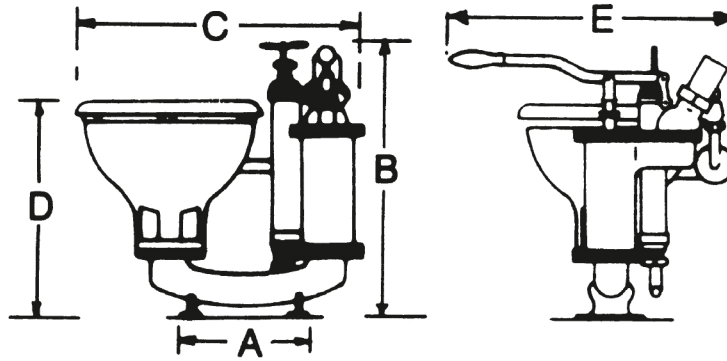

Dimensions

A - 10" (250mm)

D - 16" (405mm)

B - 21" (530mm)

E - 20" (510mm)

C - 21" (530mm)

✱ **Weight** — approx 27 kg

✱ **Discharge Pump** —
connection for 1½" bore flexible
hose or metal plumbing (2"
outlet option is available)

✱ **Rigid Handle** — only for
discharge pump

✱ **Flushing Pump** —
connections for ¾" bore flexible
hose or metal plumbing

The Lavac Toilets

ZENITH & POPULAR

- T/A Model - top action hand pump
- U/D Model - behind bulkhead HP
- 12V Model - electric pump
- 24V Model - electric pump

The Blakes Toilets

- The BABY
- The MINOR
- The VICTORY

Taylor's Gas (L.P.G.) Cookers

- The 041 Model
- The 043 Model

Taylor's Paraffin (kerosene) Cookers

- The 028 Model
- The 029 Model
- The 030 Model
- The 030L Model

Taylor's Cabin Heaters

- The 079K Model - kerosene
- The 079D Model - diesel
- The 089D Model - diesel

Schiffsausrüster

TOPLICHT

Tel.: +49 (0)40 - 88 90 100
Fax: +49 (0)40 - 88 90 1011
toplicht@toplicht.de
www.toplicht.de



BLAKES LAVAC TAYLORS