



BMV-700 series: Precision Battery Monitoring



BMV-700

Battery 'fuel gauge', time-to-go indicator, and much more

The remaining battery capacity depends on the ampere-hours consumed, discharge current, temperature and the age of the battery. Complex software algorithms are needed to take all these variables into account.

Next to the basic display options, such as voltage, current and ampere-hours consumed, the BMV-700 series also displays state of charge, time to go, and power consumption in Watts.

The BMV-702 features an additional input which can be programmed to measure the voltage (of a second battery), battery temperature or midpoint voltage (see below).

Bluetooth Smart

Use the Bluetooth Smart dongle to monitor your batteries on Apple or Android smartphones, tablets, macbooks and other devices.

Easy to install

All electrical connections are to the quick connect PCB on the current shunt. The shunt connects to the monitor with a standard RJ12 telephone cable. Included: RJ 12 cable (10 m) and battery cable with fuse (2 m); no other components needed.

Also included are a separate front bezel for a square or round display appearance, a securing ring for the rear mounting and screws for the front mounting.

Easy to program (with your smartphone!)

A quick install menu and a detailed setup menu with scrolling texts assist the user when going through the various settings.

Alternatively, choose the fast and easy solution: download the smartphone app (Bluetooth Smart dongle needed)

Midpoint voltage monitoring (BMV-702 only)

This feature, which is often used in industry to monitor large and expensive battery banks, is now for the first time made available at a low cost, to monitor any battery bank.

A battery bank consists of a string of series connected cells. The midpoint voltage is the voltage halfway along the string. Ideally, the midpoint voltage would be exactly half of the total voltage. In practice, however, deviations will be seen, that depend on many factors such as a different state of charge for new batteries or cells, different temperatures, internal leakage currents, capacities and much more.

Large or increasing deviation of the midpoint voltage, points to improper battery care or a failed battery or cell. Corrective action following a midpoint voltage alarm can prevent severe damage to an expensive battery. Please consult the BMV manual for more information.

Standard features

- Battery voltage, current, power, ampere-hours consumed and state of charge
- Remaining time at the current rate of discharge
- Programmable visual and audible alarm
- Programmable relay, to turn off non critical loads or to run a generator when needed
- 500 Amp quick connect shunt and connection kit
- Shunt selection capability up to 10.000 Amps
- VE.Direct communication port
- Stores a wide range of historical events, which can be used to evaluate usage patterns and battery health
- Wide input voltage range: 9,5 – 95V
- High current measurement resolution: 10 mA (0,01A)
- Low current consumption: 2,9Ah per month (4mA) @12V and 2,2Ah per month (3mA) @ 24V

BMV-702 additional features

Additional input to measure voltage (of a second battery), temperature or midpoint voltage, and corresponding alarm and relay settings.

BMV-700HS: 60 to 385 VDC voltage range

No additional parts needed. Note: suitable for systems with grounded minus only (battery monitor is not isolated from shunt).

Other battery monitoring options

- VE.Net Battery Controller
- High voltage VE.Net Battery Controller: 70 to 350 VDC
- Lynx Shunt VE.Net
- Lynx Shunt VE.Can

More about midpoint voltage

One bad cell or one bad battery can destroy a large, expensive battery bank. When batteries are connected in series, a timely warning can be generated by measuring the midpoint voltage. Please see the BMV manual, section 5.2, for more information.

We recommend our **Battery Balancer** (BMS012201000) to maximize service life of series-connected batteries.



BMV bezel square



BMV shunt 500A/50mV
 With quick connect pcb



BMV-702 Black



BMV-700H

Battery Monitor	BMV-700	BMV-702 BMV-702 BLACK	BMV-700HS
Supply voltage range	6,5 - 95 VDC	6,5 - 95 VDC	60 - 385 VDC
Current draw, back light off	< 4mA	< 4mA	< 4mA
Input voltage range, auxiliary battery	n. a.	6,5 - 95 VDC	n. a.
Battery capacity (Ah)	20 - 9999 Ah		
Operating temperature range	-40 +50°C (-40 - 120°F)		
Measures voltage of second battery, or temperature, or midpoint	No	Yes	No
Temperature measurement range	-20 +50°C		n. a.
VE.Direct communication port	Yes	Yes	Yes
Relay	60V / 1A normally open (function can be inverted)		

RESOLUTION & ACCURACY (with a 500 A shunt)			
Current	± 0,01A		
Voltage	± 0,01V		
Amp hours	± 0,1 Ah		
State of charge (0 - 100%)	± 0,1%		
Time to go	± 1 min		
Temperature (0 - 50°C or 30 - 120°F)	n. a.	± 1°C/°F	n. a.
Accuracy of current measurement	± 0,4%		
Accuracy of voltage measurement	± 0,3%		

INSTALLATION & DIMENSIONS	
Installation	Flush mount
Front	63mm diameter
Front bezel	69 x 69mm (2.7 x 2.7 inch)
Body diameter	52mm (2.0 inch)
Body depth	31mm (1.2 inch)

STANDARDS	
Safety	EN 60335-1
Emission / Immunity	EN 55014-1 / EN 55014-2
Automotive	ECE R10-4 / EN 50498

ACCESSORIES	
Shunt (included)	500A / 50mV
Cables (included)	10 meter 6 core UTP with RJ12 connectors, and cable with fuse for '+' connection
Temperature sensor	Optional (ASS00100000)



Victron Global Remote
The Global Remote is a modem which sends alarms, warnings and system status reports to cellular phones via text messages (SMS). It can also log data from Victron Battery Monitors, MultiPlus units, Quattros and Inverters to a website through a GPRS connection to the [VRM Portal](#). Access to this website is free of charge. VE.Direct to Global remote Interface cable needed (ASS030534000).



1000A/50mV, 2000A/50mV and 600A/50mV shunt
The quick connect PCB on the standard 500A/50mV shunt can also be mounted on these shunts.



Interface cables
- VE.Direct cables to connect a BMV 70x to the Color Control (ASS030530xxx)
- VE.Direct to USB interface (ASS030530000) to connect several BMV 70x to the Color Control or to a computer.
- VE.Direct to Global remote interface to connect a BMV 70x to a Global Remote. (ASS030534000)

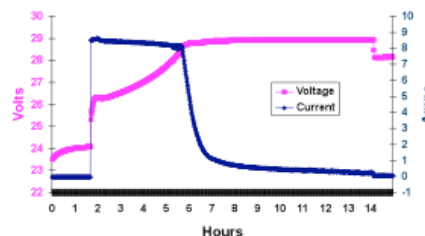

The PC application software **BMV-Reader** will show all current readings on a computer, including history data. It can also log the data to a CSV formatted file. It is available for free, and can be downloaded from our website at the [Support and downloads section](#). Connect the BMV to the computer with the VE.Direct to USB interface, ASS030530000.

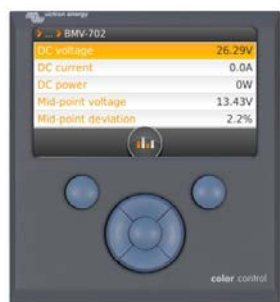

Color Control
The powerful Linux computer, hidden behind the colour display and buttons, collects data from all Victron equipment and shows it on the display. Besides communicating with Victron equipment, the Color Control communicates through CAN bus (NMEA2000), Ethernet and USB. Data can be stored and analysed on the VRM Portal.



A maximum of four BMVs can be connected directly to the Color Control. Even more BMVs can be connected to a USB Hub for central monitoring.

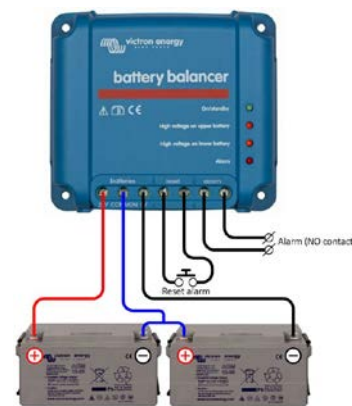
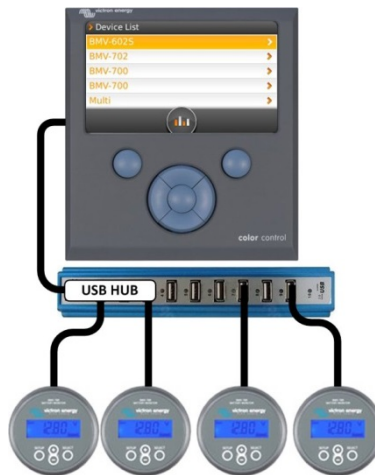

Battery Balancer (BMS012201000)
The Battery Balancer equalizes the state of charge of two series connected 12V batteries, or of several parallel strings of series connected batteries. When the charge voltage of a 24V battery system increases to more than 27V, the Battery Balancer will turn on and compare the voltage over the two series connected batteries. The Battery Balancer will draw a current of up to 1A from the battery (or parallel connected batteries) with the highest voltage. The resulting charge current differential will ensure that all batteries will converge to the same state of charge.

If needed, several balancers can be paralleled.

A 48V battery bank can be balanced with three Battery Balancers.



With the VE.Direct to Bluetooth Smart dongle real time data and alarms can be displayed on Apple and Android smartphones, tablets, macbooks and other devices.

Also use your smartphone to adjust settings!

(the VE.Direct to Bluetooth Smart dongle must be ordered separately)



See the [VictronConnect BMV app Discovery Sheet](#) for more screenshots

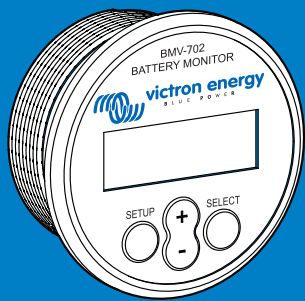

Battery monitor

BMV-700 & BMV-702

quick installation guide

Included

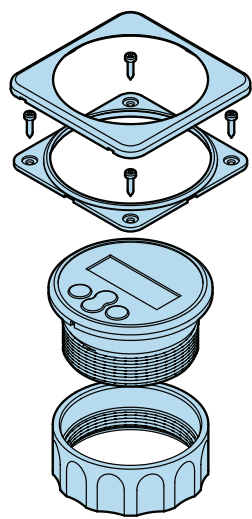

Battery monitor

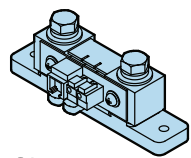

Shunt

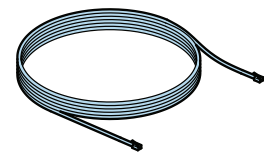

UTP cable

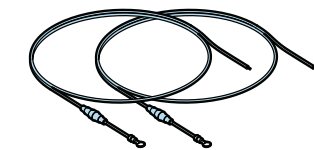

Pos. supply cable (x2)

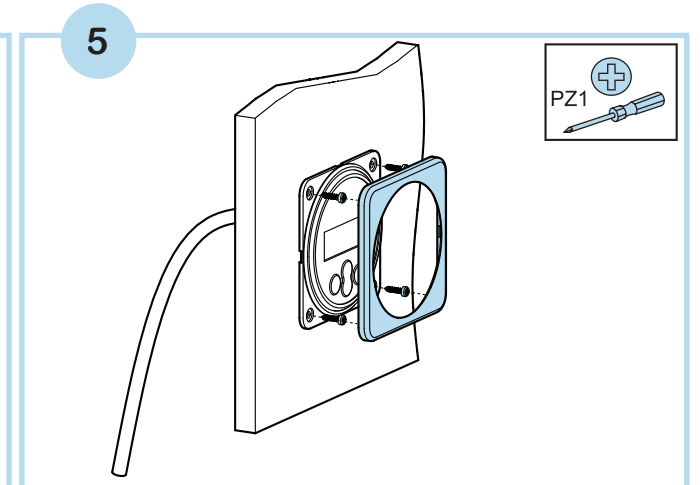
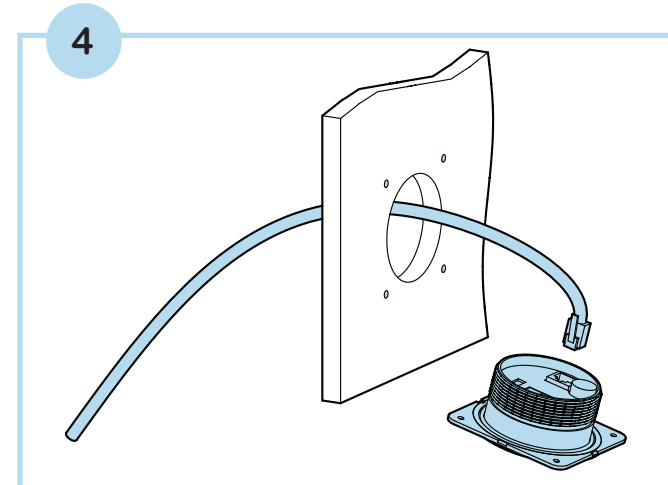
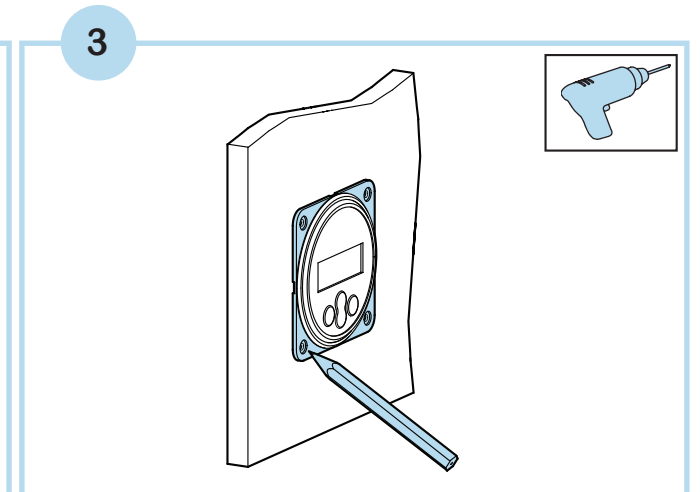
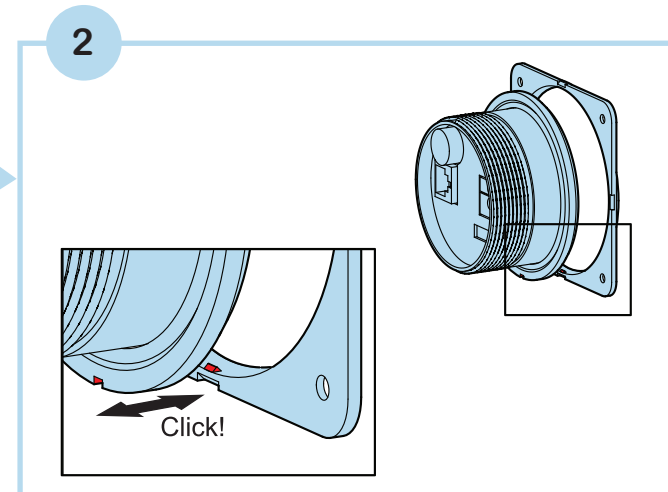
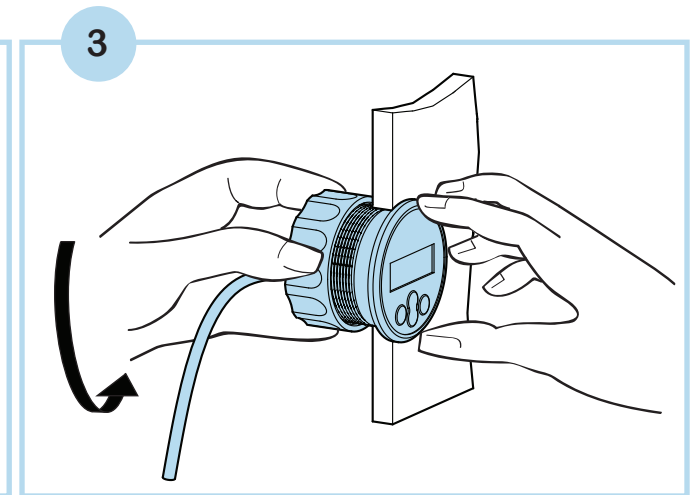
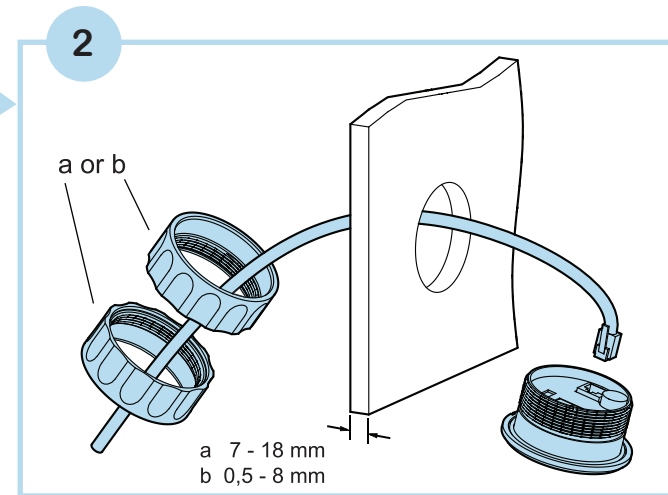
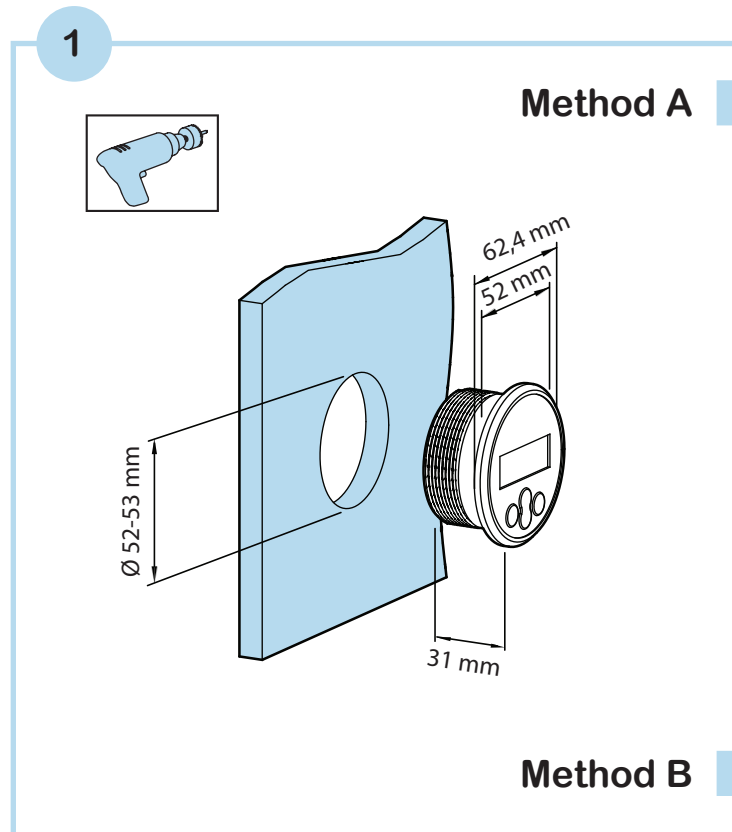

FIRST TIMERS



In case of Li-Ion batteries, several settings may have to be changed after the setup wizard is completed. *Please refer to the manual.*

The BMV will automatically adjust itself to the **nominal voltage** of **commonly** used battery systems. *Please refer to the manual.*

WARNING



Please read this guide carefully to avoid incorrect connections that can cause the battery monitor to malfunction and/or create a fire hazard.

Disconnect the negative pole of the battery before installation.

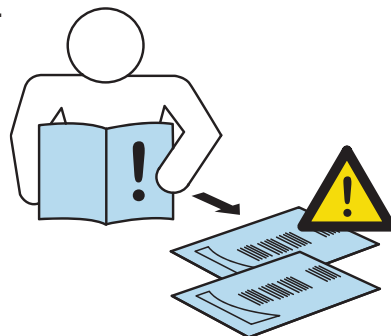

quick installation guide



Connect the negative pole of the battery last!

Battery monitor

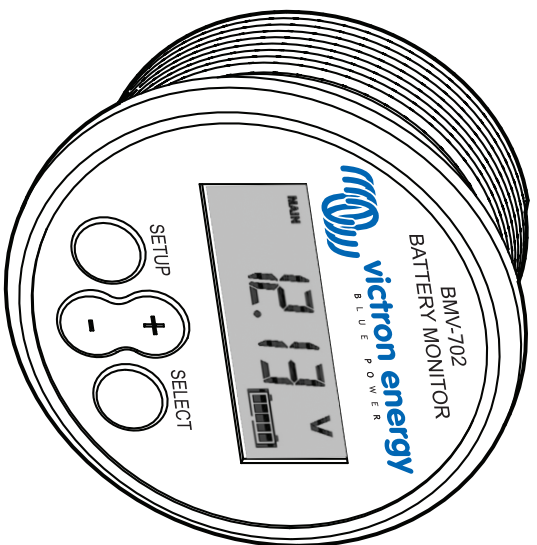

Fig. 1

Shunt

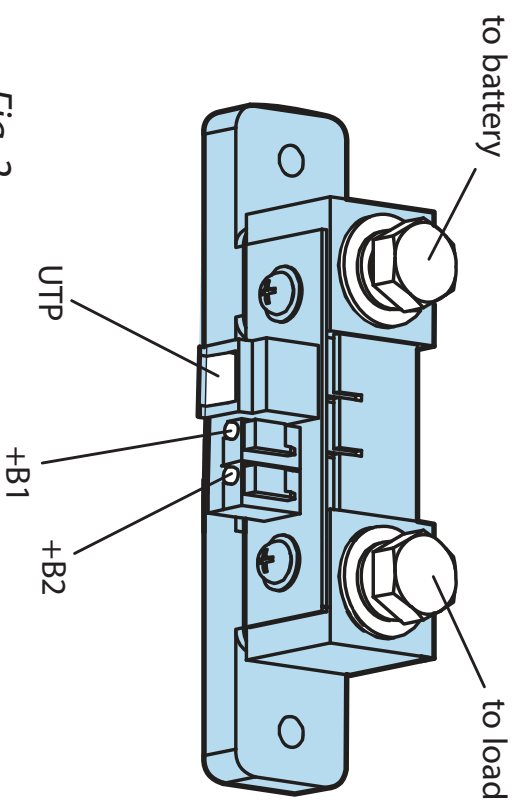

Fig. 2

Wiring diagrams



Connect the negative pole of the battery last!

BMW-700

BMW-702 configured for STARTER/AUXILIARY-battery monitoring.

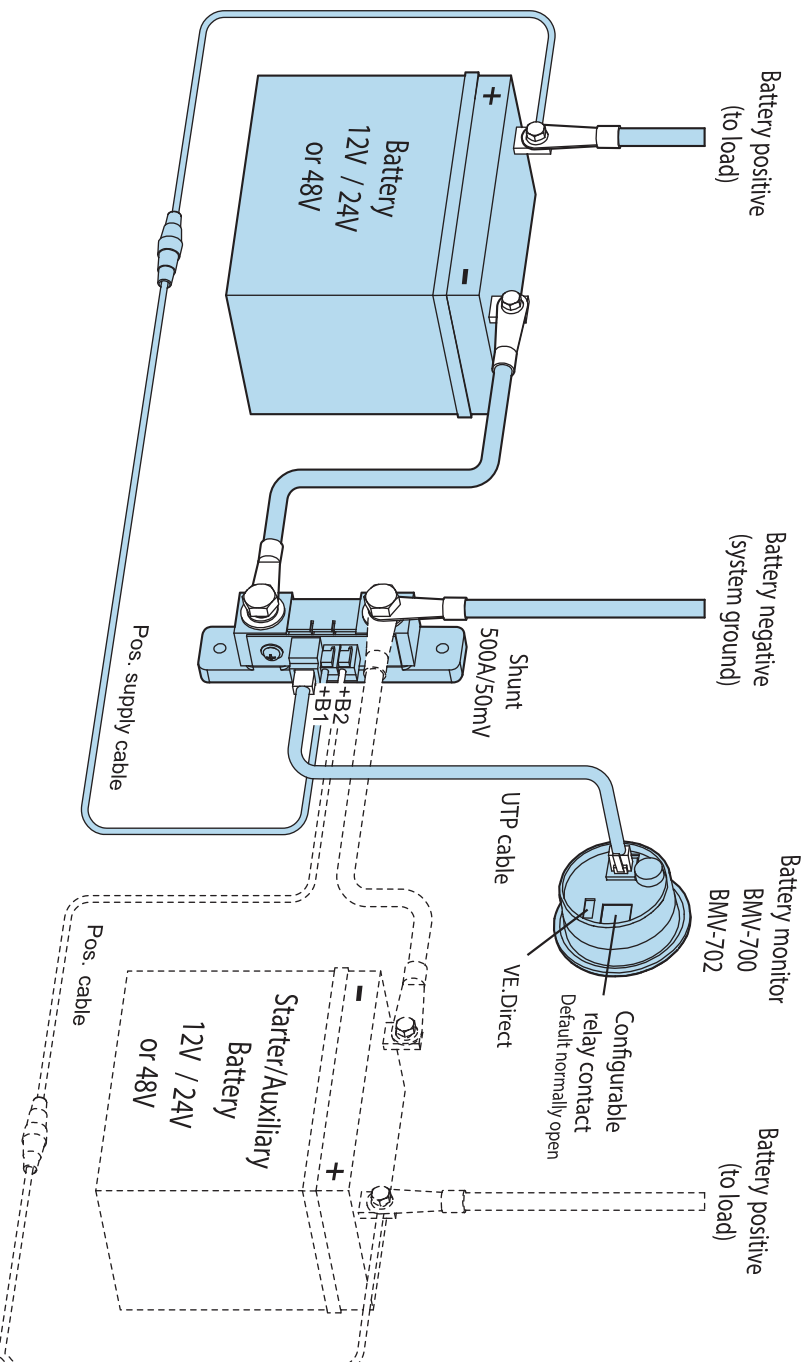

Fig. 3

BMW-702 configured for battery TEMPERATURE monitoring

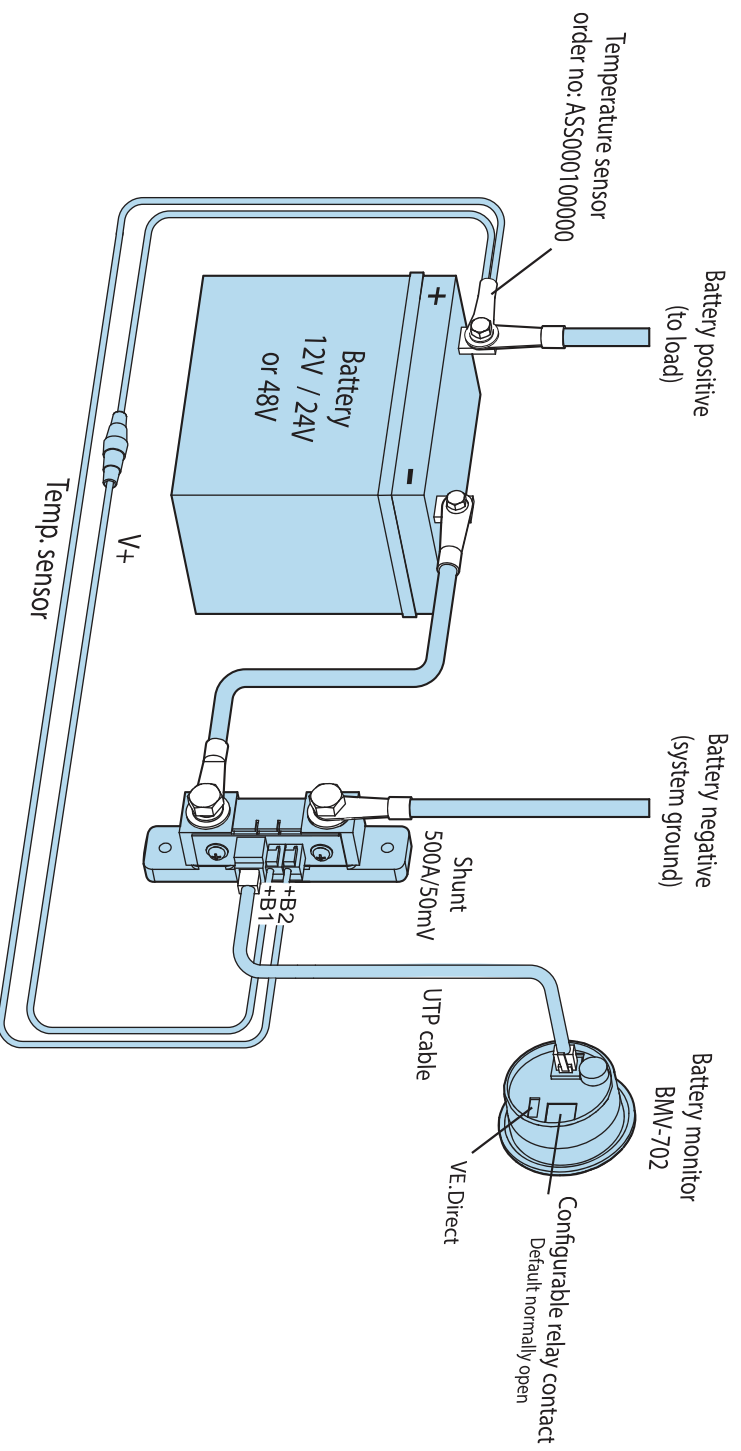

Fig. 4

Connecting multiple batteries *without* midpoint voltage monitoring : 24 V

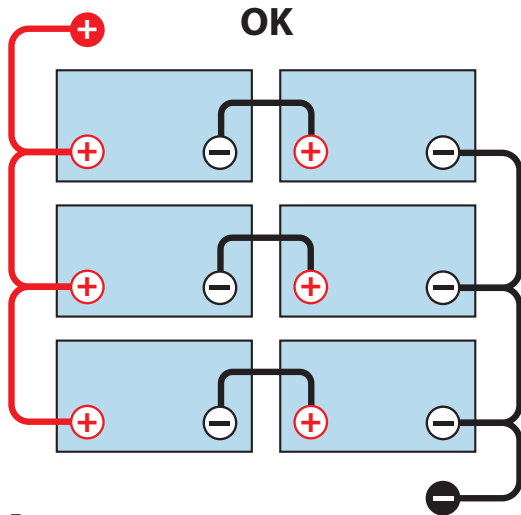

Fig. 5

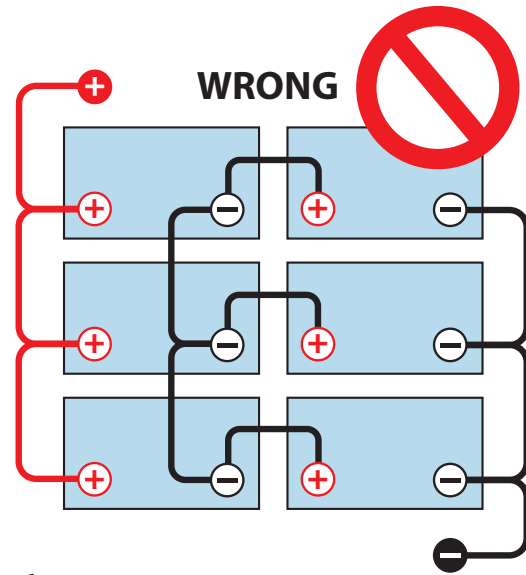

Fig. 6

Due to voltage drop over the + and - cables midpoint voltages are not identical

Applying midpoint voltage monitoring : 24 V



Always use busbars when applying midpoint voltage monitoring!
Cables to busbars must all have the same length!

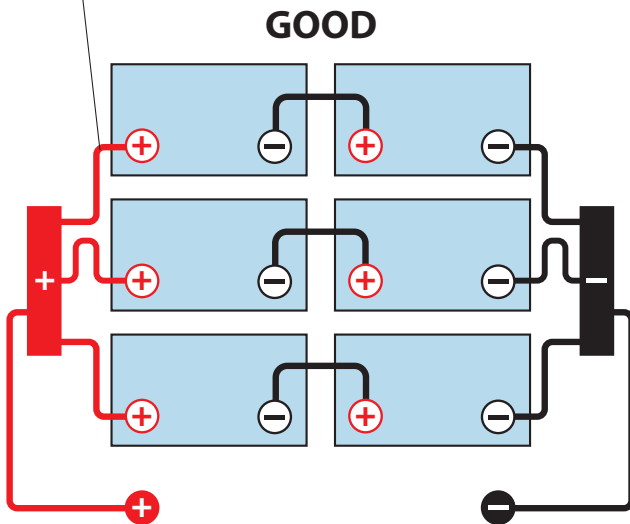

Fig. 7

Midpoints should not be interconnected: one bad battery can go unnoticed and could damage all other batteries

This cable should be short. Voltage drop over this cable will distort the midpoint measurement.

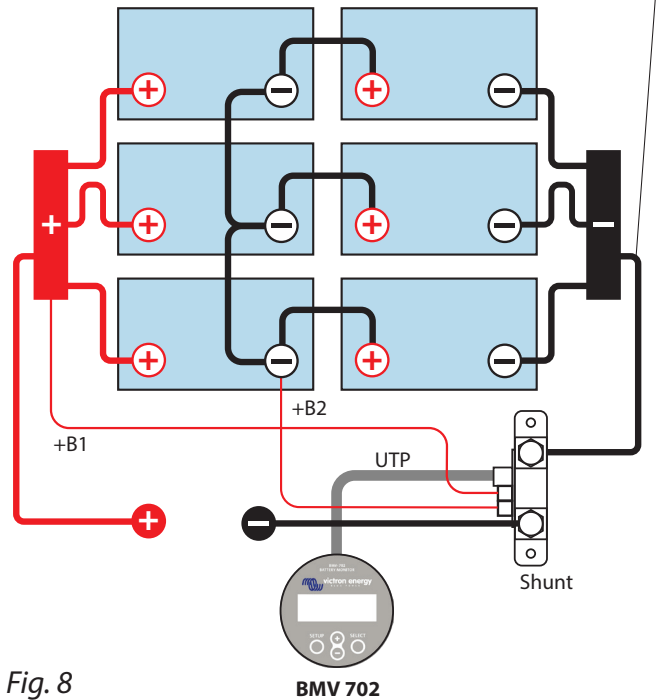

Fig. 8

Midpoints can be interconnected if corrective action is taken in case of an alarm.

In case of one string of 2 batteries +B1 and +B2 can be connected directly to the battery posts.

Connecting multiple batteries *without* midpoint voltage monitoring : 48 V

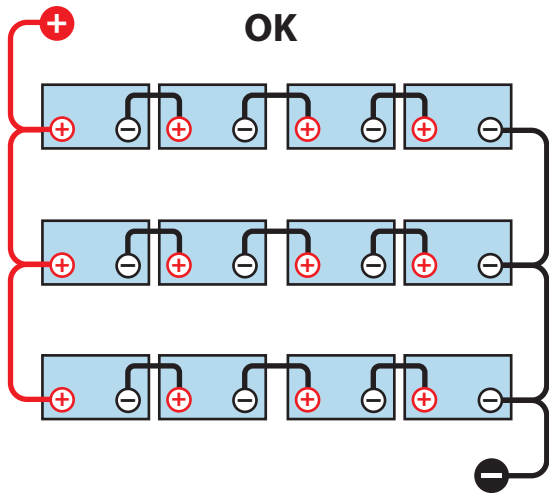

Fig. 9

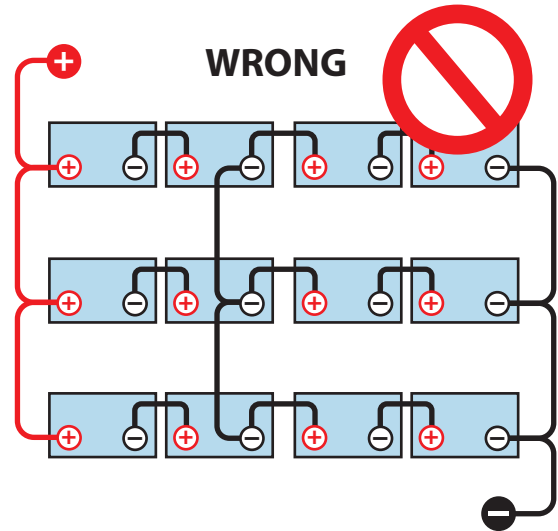

Fig. 10

Due to voltage drop over the + and - cables midpoint voltages are not identical

Applying midpoint voltage monitoring : 48 V



Always use busbars when applying midpoint voltage monitoring!
Cables to busbars must all have the same length!

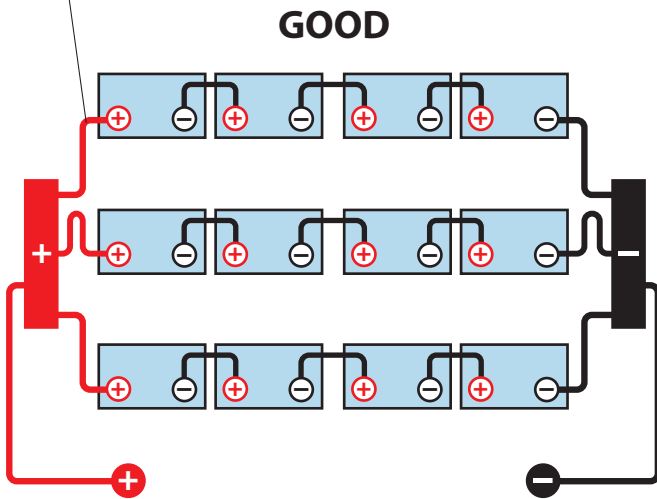

Fig. 11

Midpoints should not be interconnected: one bad battery can go unnoticed and could damage all other batteries

This cable should be short. Voltage drop over this cable will distort the midpoint measurement.

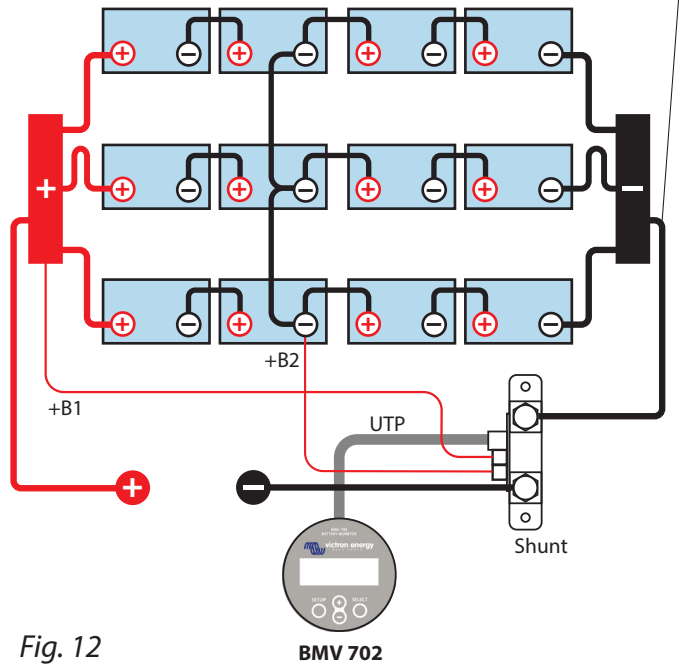

Fig. 12

Midpoints can be interconnected if corrective action is taken in case of an alarm.

In case of one string of 4 batteries +B1 and +B2 can be connected directly to the battery posts.

VictronConnect BMV app Discovery Sheet

Applicable to the BMV-700, BMV-702 and BMV-700HS series

www.victronenergy.com

VE.Direct Bluetooth Smart dongle needed (must be ordered separately)

