

Navigation Lights



Signalling Lights



Searchlights



Whistles

# TECHNICAL DOCUMENT

## DHR **230CS** - Series Cabin Controlled Searchlight



**Den Haan Rotterdam**

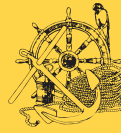

Den Haan Rotterdam



(Intentionally blank page)

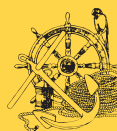

Den Haan Rotterdam



### Safety notes:

- Turn power off before inspection, installation or removal
- Don't stare directly into the LEDs, Always use eye protection when handling LEDs
- This product can be damaged by electrostatic discharge, ESD. When handling take close care before opening the drum to avoid damaging the LEDs.
- Allow lamp/fixture to cool before handling
- Do not use the searchlight if outer glass is scratched or broken

**Damage due to inappropriate handling is not covered under warranty.**

This document contains proprietary information that is protected by copyright.  
All rights reserved.

© Copyright, Den Haan Rotterdam B.V.  
Rev. B - March 2021



Den Haan Rotterdam



## PREFACE

Den Haan Rotterdam is a family-owned company established in 1922. Started as a small tinsmith, it has evolved into a globally respected producer of navigation lights, searchlights, air horns and a wide range of nautical lamps made from copper and brass. By introducing products with advanced LED-technology, DHR has safeguarded a visibly safe future for marine vessels in all weather conditions.

With the 230CS-series searchlight, DHR introduces a cabin controlled LED searchlight. The 75W LED engine produces a color output of 5.000K and an intensity close to the same performance levels of 1.000W halogen searchlights. Using the best available parabolic mirror reflectors on the market, a crisp & clear spot with no visible stray light has been ensured. The 230CS is equipped with an unique bracket design to realize an extreme downward vertical angle. This is specifically useful for close range targets. Positions on high structures or of inland navigation vessels, where high angles up to 60° are desired, the 230CS is the answer.

**DEN HAAN ROTTERDAM B.V.**

  
D.M. Den Haan  
Managing Director

## QUALITY STANDARDS



LED Technology



Light Weight Construction



Excellent Optics



IP66 Water Ingress Protection



Maintenance Friendly



Large Vertical Angle



Den Haan Rotterdam



## TABLE OF CONTENTS

1. Mounting instructions	6
2. Specifications	10
3. Dimensions	12
4. Photos	14
5. Safety, maintenance and correct use	16
6. Recommended Spare parts	17



Den Haan Rotterdam



## 1. MOUNTING INSTRUCTIONS



### Warning!

Den Haan Rotterdam does not accept responsibility for any damage if the searchlight is installed incorrectly and/or used improperly. When in doubt consult a qualified electrical technician.

### Searchlight installation

Install the searchlight in a horizontal upright position with sufficient space around the drum of the searchlight to ensure it can move freely

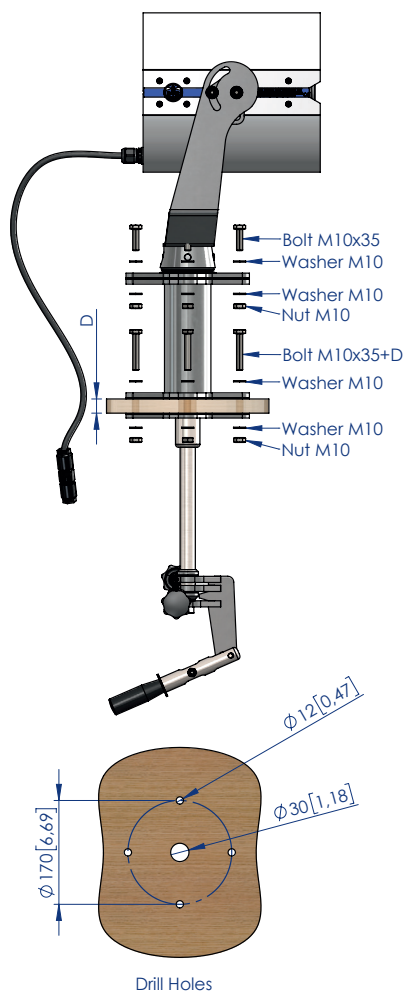

1 Mounting the searchlight

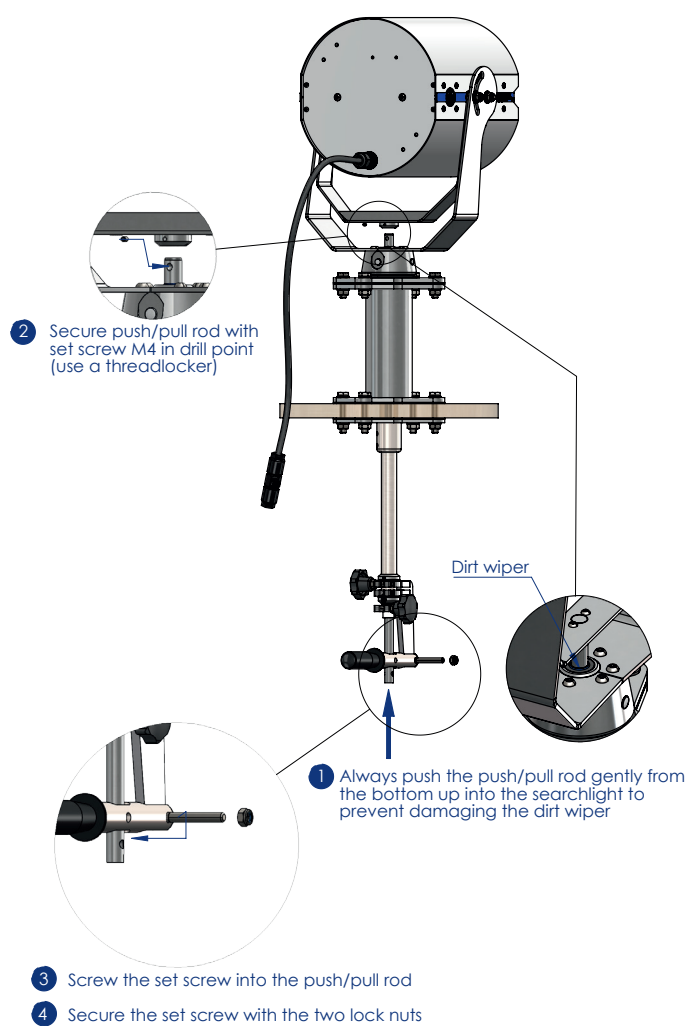

2 Installing the push/pull rod

### Fasteners

- The permissible torque should be 8 Nm
- Use only A4-grade stainless steel

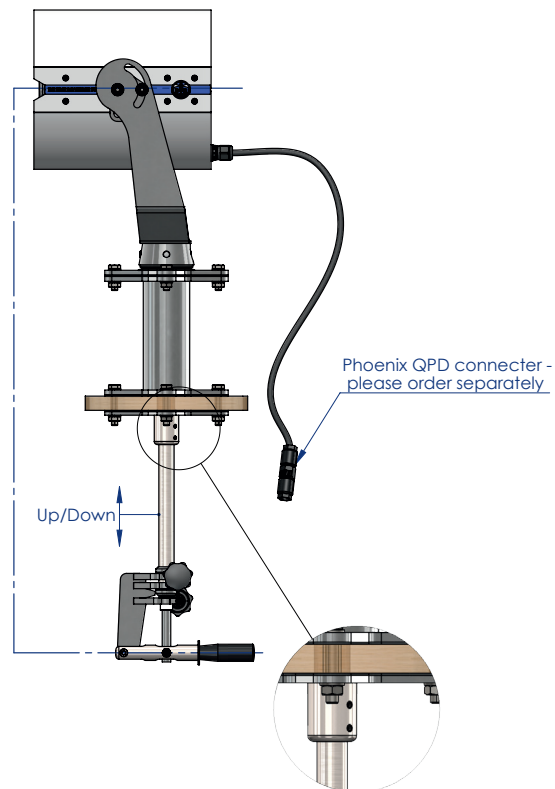
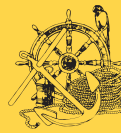

- 1 Unscrew the two set screws M6 and move the tube up and down until both the handle and head are horizontal and point in the same direction.
- 2 Tighten the set screws again (use a threadlocker)

### 3 Alignment

All sizes are in mm [inches].

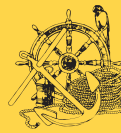

## Den Haan Rotterdam



### Electrical installation

Install the electrical wiring according to the wiring diagrams showed on page 9. Keep the distance between the power supply and LED searchlight as short as possible. Long wires will increase the voltage drop.

### Connecting the cable with Phoenix connector

(Please order separately)



1. Strip the cable and prepare the PE conductor.



2. Guide the wires into the nut and push them into the marked (1, 2, 3, etc.) wire guides until they engage.



3. Cut off the stranded wire ends so they are flush.



4. Place the union nut on the contact carrier and tighten it until it stops or use the specified torque for tightening.



5. You will feel the wires engage when they have reached the optimum screw-on width. The QUICKON nut is now screwed on so tight that it cannot be unscrewed again by hand.



6. The cable can be connected quickly and easily without using any special tools.

### Cable recommendations

EU:

- Neoprene cable H07 RN3x1.5
- Cable diameter 4 - 9 mm

USA:

- Type SJ or equivalent and comply with UL 62 and IEEE 45- 83
- Wire gauge 16 AWG
- No. of conductors 3
- Cable diameter 0,157 - 0,354 inch



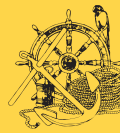

Den Haan Rotterdam



## 2. SPECIFICATIONS

### Searchlight

Model	230CSL21
<b>Dimensions</b>	
Height	436 mm [17,09 inches]
Width	306 mm [12,03 inches]
Weight	13 kg [28,7 lb]
<b>Electrical</b>	
LED-driver	115/230 VAC / 100W
Cable	Thermflex cable 3x1,5mm <sup>2</sup> - L=1,55mtr.
<b>Optics</b>	
Mirror	Parabolic mirror reflector Ø 230 mm
Range	775m [2,542.7 Feet]
Adjustable Focus	No
Beam angle	6° x 6°
Luminous intensity	600.000 cd
<b>High power LED</b>	
Model	CLU731
Luminous flux	8.767 lm
Rated LED voltage	-
Rated LED wattage	-
Average life-time	50.000 h
Color temperature	5000 K
Base	-
<b>Range of motion</b>	
Tilt	+ 30° / - 60°
PAN	360°
<b>Housing</b>	
Material	Chromated seawater resistant aluminium
Finish	UV resistant powder coating - White RAL9016
Front glass	Hardened front glass
Seals	Silicone / Neoprene, black
Operating temperature	- 25° / + 40° C
Ingress protection class	IP66 c/w Membrane vent



## Den Haan Rotterdam



### Cabin control

Model	SA10300
<b>Dimensions</b>	
Height	300 mm [11,81 inches]**
Width	-
Weight	2,2 kg [4,9 lb]
Material	Stainless steel 316

### Push/Pull rod

Model	SA20535	SA21335
<b>Dimensions</b>		
Height	535 mm [21,06 inches]**	1335 mm [88 inches]**
Width	Ø14 mm [0,51 inches]	
Weight	0,45 kg [1 lb]	1 Kg [2,2 lb]
Material	Stainless steel 316	

### Column

Model	SA30800
<b>Dimensions</b>	
Height	800 mm [31,5 inches]**
Width	Ø76 mm [3 inches]
Weight	6 kg [13,23 lb]
Material	Stainless steel 316

\*\* Custom height on request



Searchlight



Cabin control



Push/Pull rod

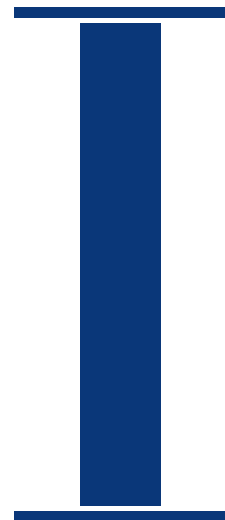

Column

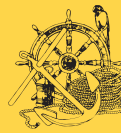

Den Haan Rotterdam



## 3. DIMENSIONS

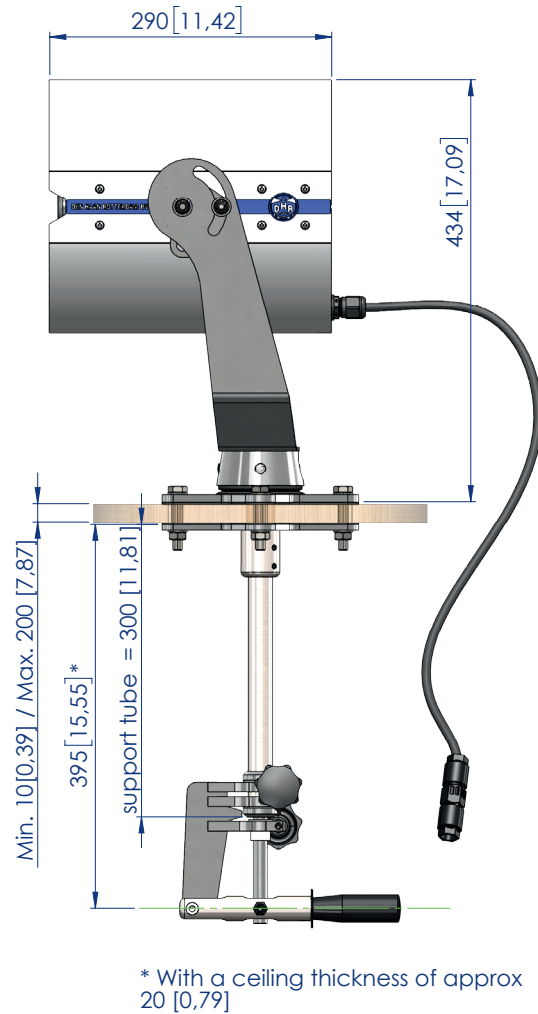
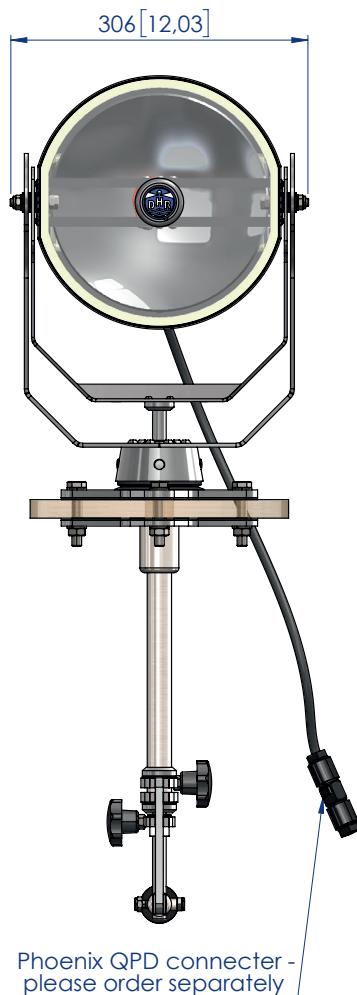



Den Haan Rotterdam

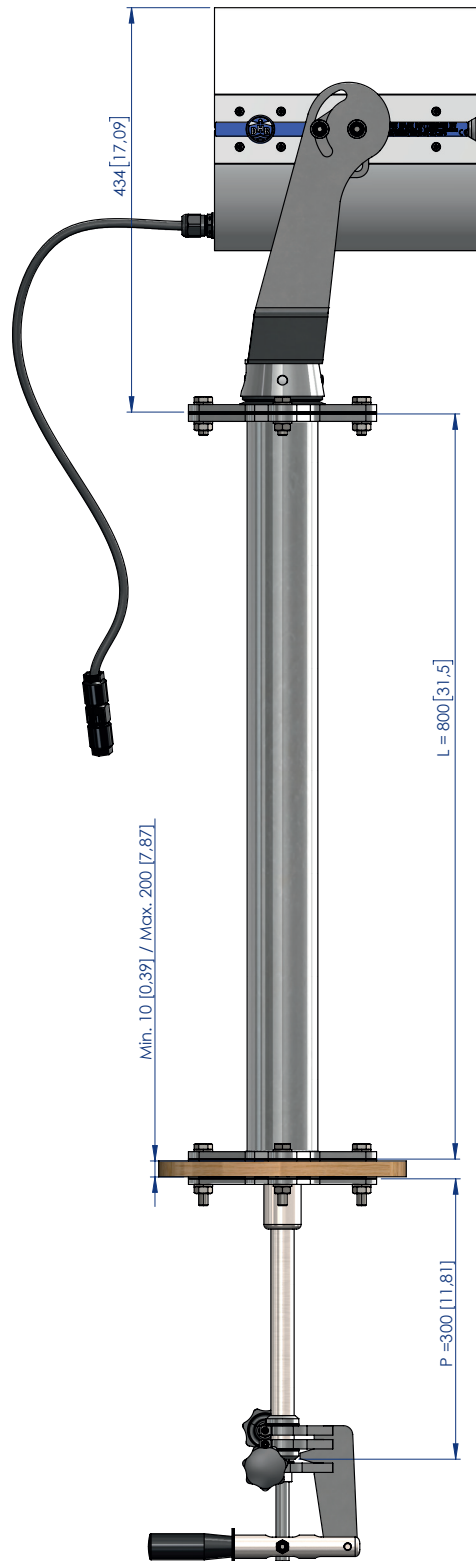

All sizes are in mm [inches].



Den Haan Rotterdam



## 4. PHOTOS



# DHR 230 CSL LED-Scheinwerfer

TOPLICHT Art-Nr. 3323-020

Stand: 31.01.2023



# TOPLICHT

Notkestraße 97 · 22607 Hamburg

Den Haan Rotterdam

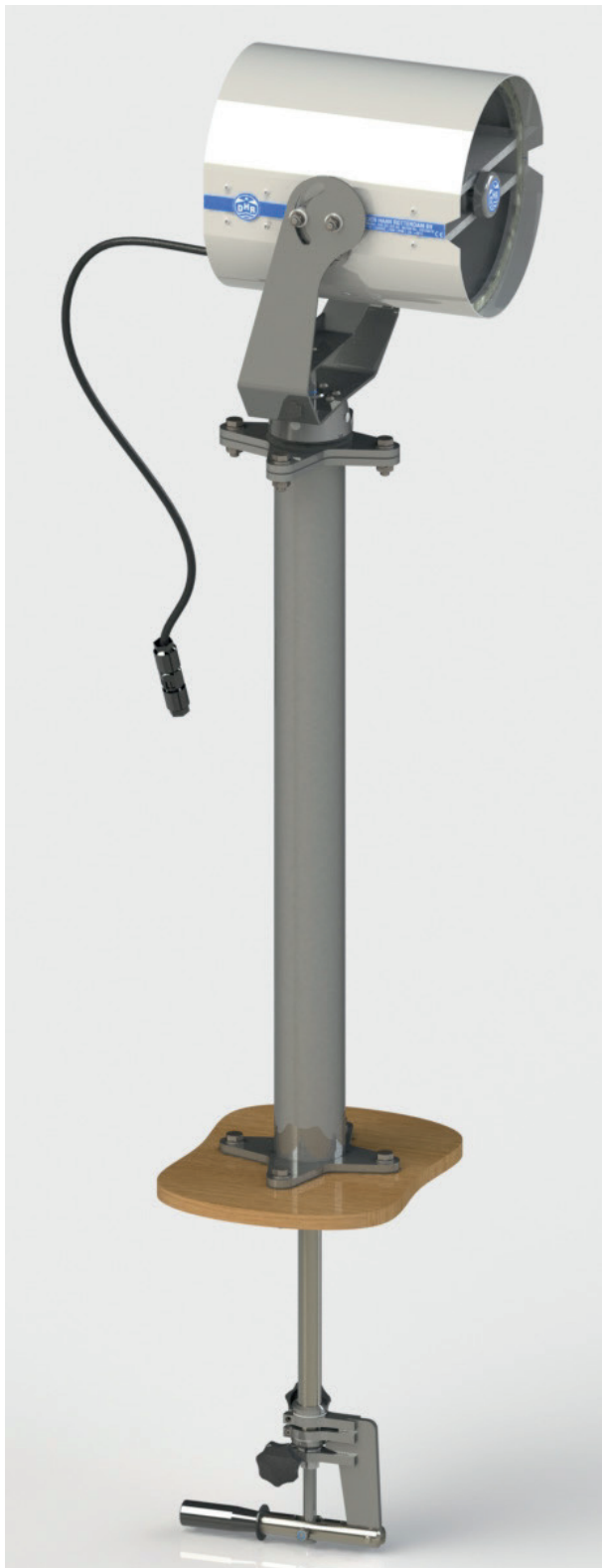



Den Haan Rotterdam



## 5. SAFETY, MAINTENANCE AND CORRECT USE



### ESD

This product, like all LED searchlights, uses semi-conductors that can be damaged by electrostatic discharge (ESD). When handling, take close care before opening the drum to avoid damaging the LEDs.

The following precautions must be taken:

- Always disconnect the power from the light before any maintenance.
- Use a conductive wrist strap attached to a good earth ground.
- Always discharge yourself by touching grounded bare metal.
- Use an approved anti-static mat to cover your work surface.
- When in doubt always consult a qualified electrician.

### Don't stare directly into the LEDs.

All cool white LEDs (5000 Kelvin and higher) contain a lot of blue and can be harmful to our eyes. Always use eye protection when handling LEDs

### Tips for correct use

- Switch off the searchlight immediately after use, this increases the life expectancy of the COB - LED
- Do not light-up objects closer than 2 metres
- Do not point the light beam at the eyes of humans or animals

### Preventive maintenance

Clean the searchlight with fresh water regularly. Do not use any aggressive cleaning agents. At least twice a year rub the V-ring and dirt wiper in with silicone grease.





Den Haan Rotterdam



## 6. RECOMMENDED SPARE PARTS

### Spare Part

No	Description	Order code
1	COB led	23980010
2	LED-holder COB led	23980020
3	LED-driver 100W	23980030
4	Mirror reflector 230	23980040
5	Front glass 230	23980050



1

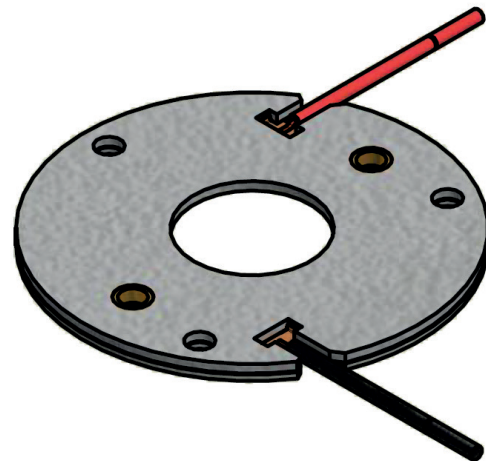

2



3



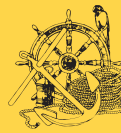

Den Haan Rotterdam



4

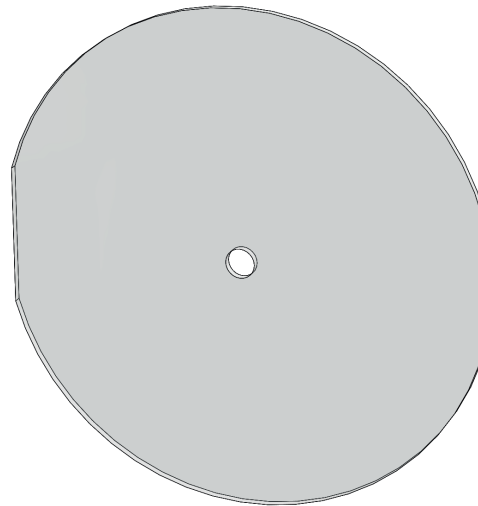

5



# ADVANCED MARITIME SIGNALLING SOLUTIONS



**Den Haan Rotterdam**

Fascinatio Boulevard 1182  
2909 VA Capelle a/d IJssel  
The Netherlands

**T** +31 (0) 10 413 07 55

**E** [sales@dhr.nl](mailto:sales@dhr.nl)

**www.dhr.nl**