

**Diverter Valve**

**Diverter Valve**

**Allows one pump to draw from two locations**

- Robust, reliable design
- Teflon® lubricated non-stick operation
- Precision machined for odour-proof seal
- Withstands sewage/black waste, saltwater and bilgewater
- Models available in either 25 mm (1") or 38 mm (1 1/2") hose connection

**Typical Uses**

- Suitable for electric or manual waste management systems
- Used in bilge and toilet waste systems
- Diverts flow to holding tank or overboard or deck pump out

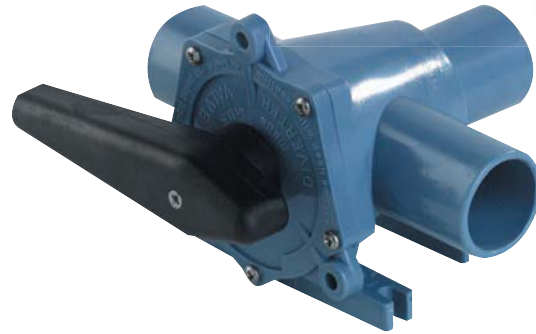

**Diverter Valve**  
5 Year Warranty

**Model Specifications**

Model	Diverter Valve	Diverter Valve
Product Code	DV5630	DV5606
Hose Connections	25 mm (1")	38 mm (1 1/2")
Materials	Main Body: Acetal, Teflon®, Handle: PTFE Polyester	

Allows one pump to draw from two locations

Note: These specifications are retail items only.  
 For details of our bulk pack range for boat builders and wholesalers - contact Whale Support.

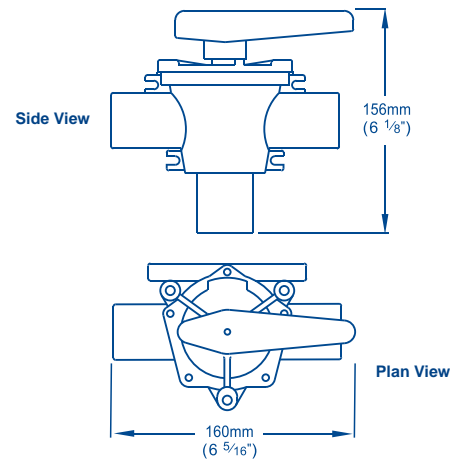

**Bilge Strainers/Strum Boxes**

**Strainer**

3/4" (19mm) Strainer with Multi-Directional Port and Non-Return Valve



**SB3422**  
(Top/Side entry)

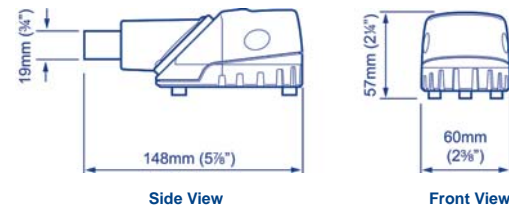

**Strainer**

1" (25mm) / 1 1/2" (38mm) Strainers available with top or side entry

Model	Top Entry Strainer	Side Entry Strainer
Product Code	SB5865	SB4222
Materials	Polypropylene	



**SB4222**    **SB5865**

