

BALL VALVE



Designed and made in New Zealand for use in marine applications above and below the water line, our Ball Valves are IMCI approved to ISO standard 9093-2, and are ideal for controlling inlet and outlet water requirements.

The body of the Ball Valve is manufactured in glass reinforced nylon composite with high impact and tensile strength resulting in a light weight unit, free from corrosion and electrolysis issues. The ball and sealing rings utilise a PTFE polymer to ensure a smooth action, and continuous ease of operation over many years. The Ball Valve is available in both BSP and NPS thread forms and can be locked in the closed position for use on toilet waste outlets.

MODELS

BSP Thread

Part #	Description	TOPLICHT Art-Nr.
90471	Ball Valve ½" BSP	6985-013
90276	Ball Valve ¾" BSP	6985-019
90242	Ball Valve 1" BSP	6985-025
90240	Ball Valve 1¼" BSP	6985-032
90235	Ball Valve 1½" BSP	6985-038
90472	Ball Valve 2" BSP	6985-050

NPS Thread

Part #	Description
90647	Ball Valve ½" NPS
90648	Ball Valve ¾" NPS
90649	Ball Valve 1" NPS
90650	Ball Valve 1¼" NPS
90651	Ball Valve 1½" NPS
90652	Ball Valve 2" NPS

KEY FEATURES

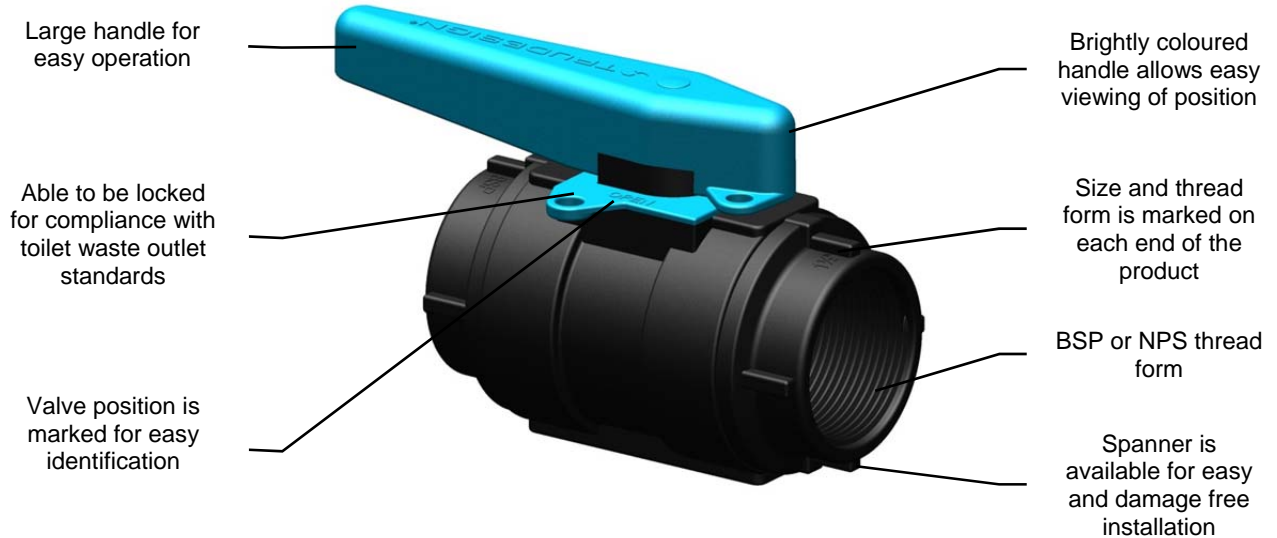

Glass reinforced nylon composite construction

- Light weight and high strength
- Corrosion resistance
 - Long life
 - Minimal maintenance
 - No corrosion deposits to remove
- Electrically non conductive
 - No electrical bonding
 - Suitable for use on all hull types - aluminium, steel, wood or FRP hulls
- UV resistant
 - Will not break down in the sun
- Chemical resistant
 - Impervious to diesel, petrol, oil and antifouling paints
- Large operating temperature range
 - -40° to 80°C (-40° to 176°F)

PTFE enhanced sealing and sliding elements

- Reduced friction for easy operation
- Reduction in blockages due to fouling

High quality

- Quality materials from accredited suppliers
- Standards approved through IMCI to ISO standard 9093-2
- Every Ball Valve is leak tested during manufacture

STANDARDS

Tru-Design Ball Valves are certified by the International Marine Certification Institute (IMCI) to meet;

ISO 9093-2 Small craft -- Seacocks and through-hull fittings -- Part 2: Non-metallic

In meeting ISO 9093-2, our Ball Valves have been tested with a 155kg load hanging off a hose fitting while connected to our Skin Fitting as shown.



The locking feature allows the Ball Valve to comply with US Coast Guard Regulation 33 CFR 159.7 and ISO Standard 8099 for locking of toilet waste outlets.

SPECIFICATIONS

The connecting threads on each end of the Ball Valves are a parallel thread form. These parallel threads are designed so that thread tape is wound onto a male skin fitting or tail then screwed into the ball valve. The advantage of parallel threads over tapered is that there is maximum engagement between the mating threads providing a strong and watertight seal.

Mixing parallel and tapered threads can cause strength and sealing problems as the engagement can frequently be only a few turns.

Ball Valves are available in;

- BSP (British Standard Pipe)
- NPS (National Pipe Straight)

WEIGHT

Internal Diameter	Thread Size	Weight (g)	Weight (oz)
19mm [¾"]	½", ¾", 1"	300	10.6
32mm [1¼"]	1¼", 1½"	450	15.9
52mm [2"]	2"	700	24.7

DIMENSIONS

All dimensions nominal.

19mm [$\frac{3}{4}$ "] ID $\frac{1}{2}$ " BSP, $\frac{3}{4}$ " BSP, 1" BSP
 $\frac{1}{2}$ " NPS, $\frac{3}{4}$ " NPS, 1" NPS

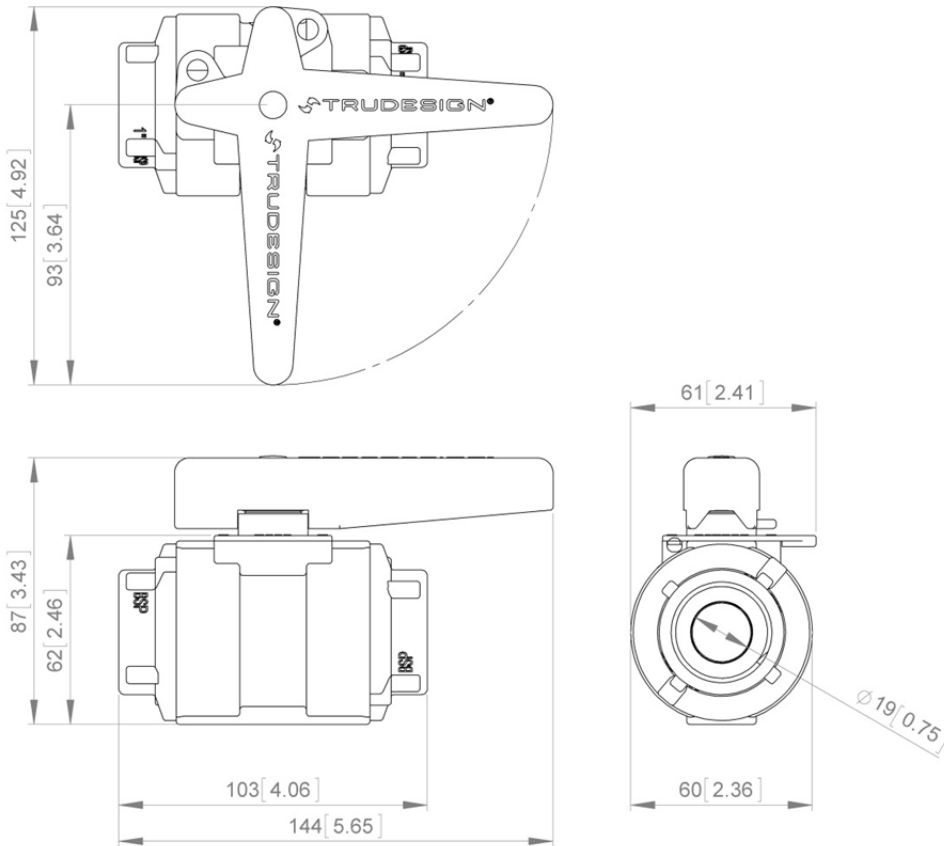

32mm [1¼"] ID 1¼" BSP, 1½" BSP
 1¼" NPS, 1½" NPS

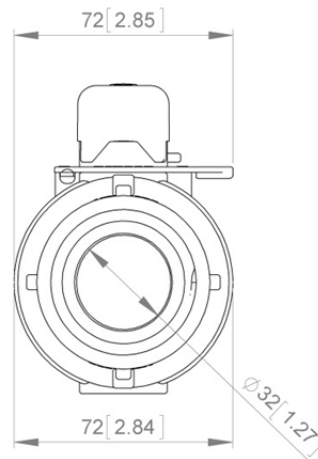
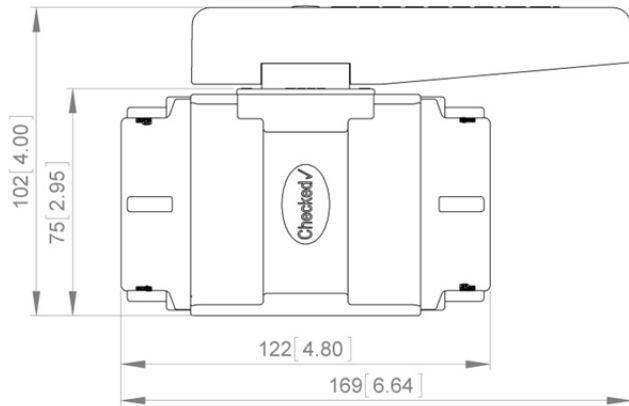
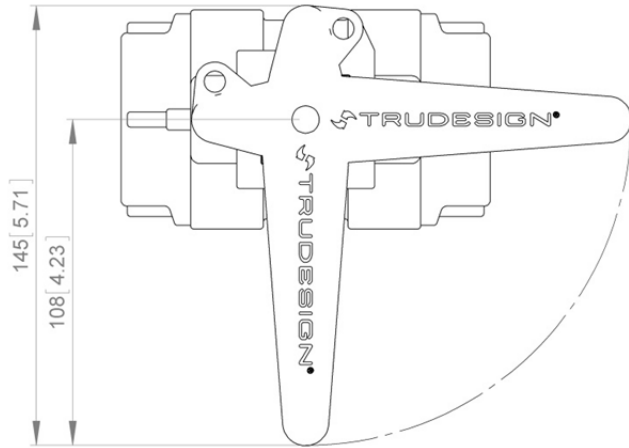

52mm [2"] ID

2" BSP

2" NPS

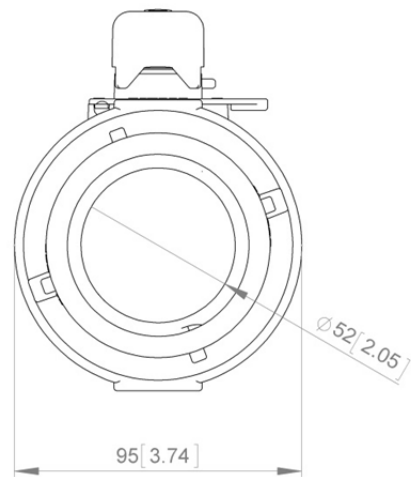
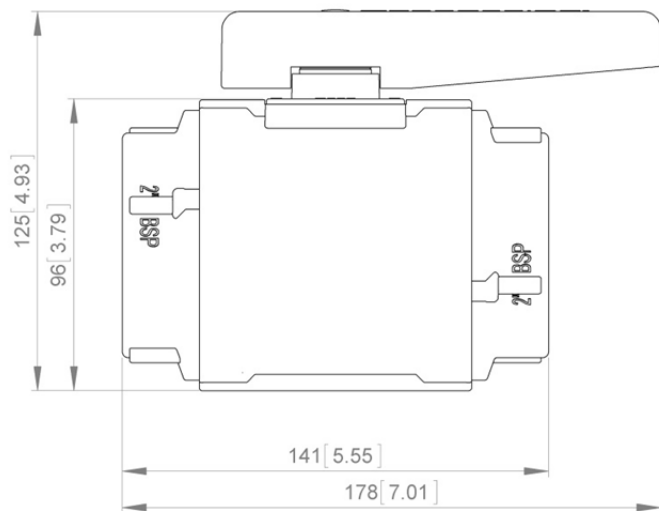
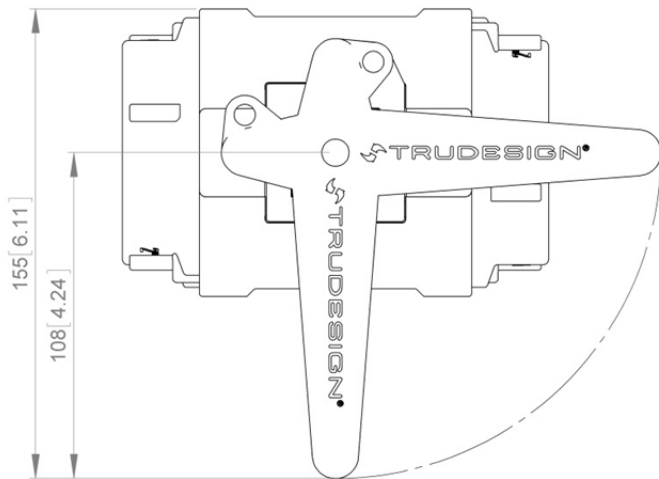

INSTALLATION

If the valve is to be assembled to a skin fitting, ensure that the position of the skin fitting is such that it will be in a protected area, but readily accessible.

Ensure threads of mating fittings have a parallel thread and it is clean and undamaged.

Apply sealing tape to the thread of the Skin Fitting or Tail.

Screw ball valve onto the mating fitting using the correct Ball Valve Spanner (available from Tru-Design), or other appropriate tool.

Tighten any attached fittings to a maximum of 16Nm (12ft/lbs).

Check that the final position of the Ball Valve is such that it allows full movement of the handle from the open to closed position, and that it is clear of objects which may cause inadvertent operation.

NOTE - It is recommended that the padlock is not fitted to the exposed tag in the open position. There is a risk that in an emergency situation the seacock cannot be closed easily.

Part #	Description	TOPLICHT Art-Nr.
90476	Spanner Ball Valve ½"	6985-101
90477	Spanner Ball Valve ¾" & 1"	6985-102
90478	Spanner Ball Valve 1¼" & 1½"	6985-103
90479	Spanner Ball Valve 2"	6985-104



SERVICING

As composite Ball Valves are immune to corrosion, minimal servicing is required.

The Ball Valve should be operated at regular intervals to ensure barnacles etc do not block the operation of the valve.

Tru-Design Plastics Ltd. accepts no responsibility for Products which are improperly installed or tampered with. Although the information presented in this product information sheet is believed to be accurate and reliable, no responsibility for inaccuracies can be assumed by Tru-Design Plastics Ltd. This performance data is typical only and variations due to component manufacturing tolerances are normal. Tru-Design Plastics Ltd. reserves the right at any time to change performance characteristics or specifications without prior notice.
Tru-Design Plastics Ltd, all rights reserved.

LOAD BEARING COLLARS - ABYC H-27 RATED

TRUDESIGN® Load Bearing Collars are designed for use with TRUDESIGN® Skin Fittings and Ball Valves.

Available in three sizes;

Small (for ½", ¾" or 1" assemblies)

TOPLICHT Art-Nr. 6985-105



Medium (for 1¼" or 1½" assemblies)

TOPLICHT Art-Nr. 6985-106



Large (for 2" assemblies)*



DAME CATEGORY WINNER



NOMINATIE
 PRODUCT
 VAN HET JAAR
 2016

A Load Bearing Collar will allow an assembly of a Skin Fitting - Ball Valve – Tail to withstand a 500 lb. (227 kg) load applied to the Tail (inboard end), for a minimum of 30 seconds – complying with North American ABYC H-27 standards. Compliance to this standard is mandatory for all vessels sold into the United States.

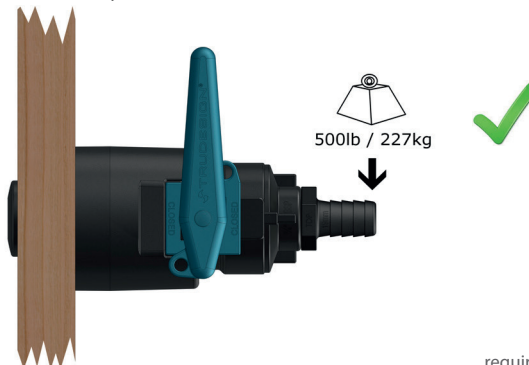

* TRUDESIGN® 2" size assemblies currently meet H-27 standards without requiring a Load Bearing Collar to be installed.

Features & Benefits:

Feature:	Benefit:
Award-winning	DAME Category Winner 2015 – Marina Equipment, Boatyard Equipment, and Boat Construction Tools & Materials – Marine Equipment Tradeshow (METS) 2015 HISWA 'Product of the Year' Nominee 2016 – HISWA Amsterdam Boat Show 2016
ABYC H-27 compliance for ½", ¾", 1", 1¼", 1½", & 2" size assemblies	Strength and peace-of-mind. Rates assemblies to withstand a static load of 500 lb (227 kg) at the Tail end for a minimum of 30 seconds
Compact footprint	Designed to work within existing space confinements (is no larger in diameter than the Ball Valve + handle)
No additional bolts or fasteners through or on to the hull	Unlike flanged seacocks, the TRUDESIGN® Load Bearing Collars work without needing to be fastened to the hull
Ability to retrofit to existing Skin Fitting - Ball Valve assemblies	Can make any existing TRUDESIGN® Skin Fitting - Ball Valve - Tail assembly compliant to ABYC H-27 simply by removing the Ball Valve, placing the Collar onto the Ball Valve, trimming the Skin Fitting's thread length (only if necessary – see following page), then refitting the Collar & Ball Valve back on to the Skin Fitting
Compatible with all hull materials across a range of thicknesses – see installation notes	Can be used on aluminium, steel, wood, GRP or composite hulls. Skin Fittings may need to be reduced in length for optimum strength – see installation notes

Shrouded protection	Protects vulnerable areas, such as the exposed thread of the Skin Fitting, from being inadvertently struck by loose items in the hull
Fool-proof assembly	If not installed correctly (e.g. if the Skin Fitting thread has not been reduced to a sufficient length) the Collar will be loose and will be able to move up and down the Ball Valve. When installed correctly, the Collar will be snug and not move
Manufactured from a glass-reinforced nylon composite	High strength and light weight
Immune to corrosion and electrolysis	Long life with no concerns over decreased performance due to corrosion. No bonding required

Technical Information:

The following tables list the minimum, optimal and maximum hull thickness required for each of the different sizes and types of Skin Fitting (Dome headed or Recessed) to comply with ABYC H-27 standards.

Important Notes:

- 1.) If hull thickness is less than the 'min.' value listed, a spacer/packer should be used on the inside of the hull underneath the Skin Fitting Washer and Nut. This should also apply if installed in a position where there is excessive curvature on the hull interior.
- 2.) The thread length of a Skin Fitting can be shortened by cutting with a hacksaw or similar tool. Measure the remaining thread length from the top of the Skin Fitting Nut as pictured in the table's right-hand column and ensure the thread length after cutting falls between the **min.** and **MAX** values. Remove any ragged internal edges with a small file.
- 3.) At the '**Optimal**' hull thickness, there will be full thread engagement between the Skin Fitting and Ball Valve. Reducing the Skin Fitting's thread length will not be required.
- 4.) If hull thickness exceeds the '**MAX.**' value listed, there will be insufficient thread engagement between the Skin Fitting and Ball Valve in order to achieve ABYC H-27 compliance. If possible, use a larger sized TRUDESIGN® Skin Fitting or consider using a TRUDESIGN® Recessed Skin Fitting.



Load Bearing Collar – Small	min. Hull Thickness	MAX. Hull Thickness	Remaining thread length required on Skin Fitting (for Ball Valve)	
½" Skin Fitting + ½" Ball Valve	30mm	35mm		
½" Recessed Skin Fitting + ½" Ball Valve	30mm	38mm		
Load Bearing Collar – Small	min. Hull Thickness	Optimal Hull Thickness	MAX. Hull Thickness	Remaining thread length required on Skin Fitting (for Ball Valve)
¾" Skin Fitting + ¾" Ball Valve	20mm	30mm	35mm	
1" Skin Fitting + 1" Ball Valve				
¾" Recessed Skin Fitting + ¾" Ball Valve	20mm	35mm	40mm	
1" Recessed Skin Fitting + 1" Ball Valve				

Load Bearing Collar – Medium	min. Hull Thickness	Optimal Hull Thickness	MAX. Hull Thickness	Remaining thread length required on Skin Fitting (for Ball Valve)
1¼" Skin Fitting + 1¼" Ball Valve	24mm	36mm	48mm	
1½" Skin Fitting + 1½" Ball Valve				
1¼" Recessed Skin Fitting + 1¼" Ball Valve	24mm	41mm	53mm	
1½" Recessed Skin Fitting + 1½" Ball Valve	24mm	42mm	54mm	
Load Bearing Collar – Large	min. Hull Thickness	Optimal Hull Thickness	MAX. Hull Thickness	Remaining thread length required on Skin Fitting (for Ball Valve)
2" Skin Fitting + 2" Ball Valve	24mm	36mm	50mm	

Approvals:

- ABYC (American Boat & Yacht Council) H-27 (*SEACOCKS, THRU-HULL FITTINGS, AND DRAIN PLUGS*) compliance when a Load Bearing Collar is used with TRUDESIGN® Skin Fittings, Ball Valves, and Tails – Independently verified by IMANNA Laboratory Inc., Rockledge FL, USA. (Test Report 20143-1). **Note: Not tested with other manufacturer's fittings.**
- TRUDESIGN® Skin Fittings and Ball Valves are certified by Bureau Veritas & IMCI to ISO 9093-2 standards (*Small craft — Seacocks and through-hull fittings — Part 2: Non-metallic*), for use above and below the waterline.



New Installation:

- Perform a 'dry fit' of parts first to determine the final handle position of the Ball Valve, and whether or not the Skin Fitting thread length needs to be trimmed i.e. measure the hull thickness and/or the remaining thread length on the Skin Fitting (after the Washer and Nut are fitted). Check it meets the thread length requirements listed on Pages 2-3. It may be easier to trim the Skin Fitting before installation, if the installed location is difficult to access.
- Clean off the inside and outside of the hull where the old thru-hull fitting was removed. In the case of composite and wooden hulls TRUDESIGN® recommends using Epoxy-West system or a similar two-pot epoxy that mixes to a paste (and not a liquid type resin these may run and create an undesirable finish). A marine grade sealant such as SIKAFLEX® 291i or 3M™ Fast Cure 5200 may also be used instead.
- Apply the epoxy paste or sealant to the underside of the Skin Fitting's flange and a small way up the threaded diameter **but no further up than the thickness of the hull. Note: This is important as any adhesive further up the thread may prevent the Nut or Ball Valve from screwing on.**

- 4.) Insert the Skin Fitting through the hull from the outside. The easiest way of holding the Skin Fitting is to use a **TRUDESIGN®** Skin Fitting Install Tool or to insert one or two fingers inside the Skin Fitting then offer it up to the hole. The paste should be thick enough to hold the Skin Fitting in place and not drip or run down the hull's exterior. Go inside the hull to fit the Washer and Nut.
 - 5.) If there is a large gap between the hole in the hull and the Skin Fitting, carefully fill this gap with more epoxy paste, again ensuring to avoid the upper part of the thread where the Nut and Ball Valve will attach.
 - 6.) Drop the Washer over the top of the thread. **Note: For excessive curvature in the hull a suitable curved packer should be fitted between the hull and the Washer.**
 - 7.) Hold the thread down near the Washer and screw on the Nut. Once the Nut is down far enough that you can hold the Skin Fitting thread above it do so and continue to screw down onto the Washer until only finger tight. On the outside of the hull clean off any excess epoxy. **Tip: Use an angled tool or putty knife to blend the epoxy or sealant around the Skin Fitting flange and hull so it is easier to clean when sanding and antifouling in the future.**
 - 8.) After the recommended curing time (see manufacturer's notes) tighten the nut to a maximum 15ftlb (or hand-tight plus another ½ a turn as a general rule-of-thumb). There is no need to over-tighten the Nut as the epoxy/sealant has now made the Skin Fitting an integral part of the hull.
 - 9.) Measure the exposed length of thread on the Skin Fitting (measured from the top/inboard face of the Nut) and ensure it meets length requirements listed in the tables on Pages 2-3, otherwise cut down to the correct length. Clean any swarf or ragged internal edges with a small file.
 - 10.) Apply a suitable marine grade thread sealant such as SIKAFLEX® 291i or 3M™ Fast Cure 5200, or PTFE thread sealing tape to the Skin Fitting's thread. **Tip: Adding a small bead of sealant to the underside of the Load Bearing Collar can prevent noise through engine vibrations etc.**
 - 11.) Fit the Ball Valve into the Load Bearing Collar.
 - 12.) Holding the Ball Valve and Load Bearing Collar together, offer them up to the Skin Fitting and turn both together, tightening all the way until the Collar is snug and sandwiched in place between the hull and Ball Valve.
 - 13.) Keep tightening, or loosen off very slightly until the handle of the Ball Valve is in its desired final position.
 - 14.) There should be no movement in the Load Bearing Collar. If there is, the Skin Fitting's thread is too long and will need to be reduced in length by further trimming.
- Your thru-hull assembly is now compliant to ABYC H-27 requirements.

Retrofit Installation (TRUDESIGN® parts only):

- 1.) Remove any pipework from the Ball Valve's Tail fitting.
 - 2.) Using a **TRUDESIGN®** Ball Valve Spanner unscrew the Ball Valve from the Skin Fitting.
Tip: If a TRUDESIGN® Ball Valve Spanner is not available, wrap a cloth or rag around the Ball Valve for protection, then carefully grip and unwind the Ball Valve using multi-grip pliers.
 - 3.) Measure the exposed length of thread on the Skin Fitting and ensure it meets the length requirements listed in the tables on Pages 2-3, otherwise cut it down to the correct length. Clean any swarf or ragged internal edges with a small file.
 - 4.) Reapply a suitable marine grade thread sealant such as SIKAFLEX® 291i or 3M™ Fast Cure 5200, or PTFE thread sealing tape to the Skin Fitting's thread. **Tip: Adding a small bead of sealant to the underside of the Load Bearing Collar can prevent noise through engine vibrations etc.**
 - 5.) Fit the Ball Valve into the Load Bearing Collar.
 - 6.) Holding the Ball Valve and Load Bearing Collar together, offer them up to the Skin Fitting and turn both together, tightening all the way until the Collar is snug and sandwiched in place between the hull and Ball Valve.
 - 7.) Keep tightening, or loosen off very slightly until the handle of the Ball Valve is in desired final position.
 - 8.) There should be no movement in the Load Bearing Collar, if there is, the Skin Fitting's thread is too long and will need to be reduced in length by further trimming.
- Your thru-hull assembly is now compliant to ABYC H-27 requirements.

Part Numbers:

Model / Size	Weight	Part Number
Load Bearing Collar ABYC Rated - Small (to suit ½", ¾" or 1" sizes)	150 grams / 5.29 oz	90856
Load Bearing Collar ABYC Rated - Medium (to suit 1¼" or 1½" sizes)	165 grams / 5.82 oz	90857
Load Bearing Collar ABYC Rated - Large (to suit 2" size)	285 grams / 10.05 oz	90920



Dimensions:

Dimensions are in millimetres & [inches]
All dimensions nominal

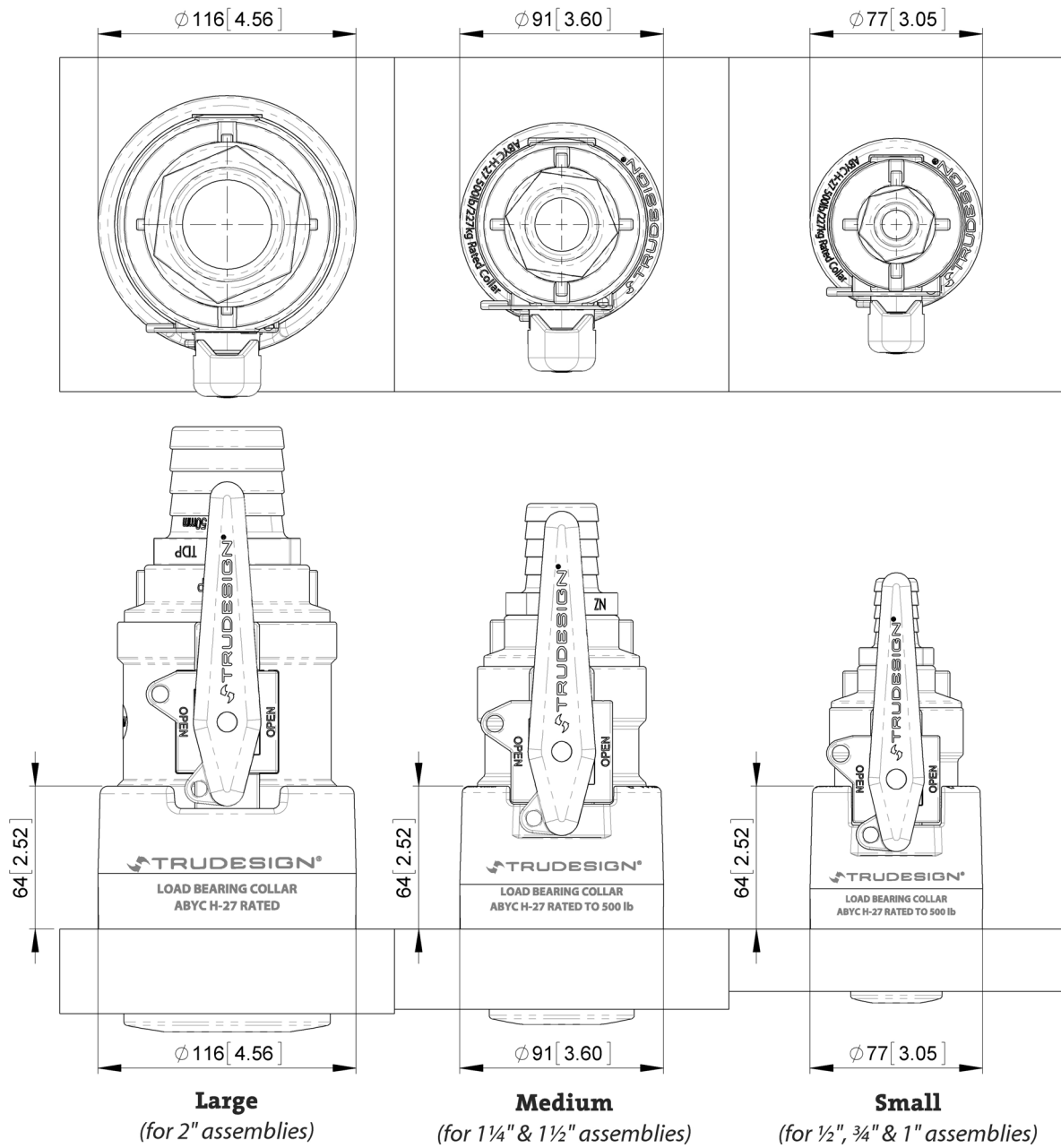

TruDesign Plastics Ltd. accepts no responsibility for products which are improperly installed or tampered with. Although the information presented in this product information sheet is believed to be accurate and reliable, no responsibility for inaccuracies can be assumed by TruDesign Plastics Ltd. This performance data is typical only and variations due to component manufacturing tolerances are normal. TruDesign Plastics Ltd. reserves the right at any time to change performance characteristics or specifications without prior notice. TruDesign Plastics Ltd. 2016, all rights reserved.